

# Installation and Operating Manual

## COMMERCIAL GAS WATER HEATERS



POWER VENTED GAS MODELS  
WITH HOT SURFACE IGNITION

NOT FOR USE IN MANUFACTURED (MOBILE) HOMES  
MODELS BTF-80 SERIES 210, 211



**WARNING:** If the information in these instructions is not followed exactly, a fire or explosion may result causing property damage, personal injury or death.

- Do not store or use gasoline or other flammable vapors and liquids in the vicinity of this or any other appliance.
- **WHAT TO DO IF YOU SMELL GAS:**
  - Do not try to light any appliance.
  - Do not touch any electrical switch; do not use any phone in your building.
  - Immediately call your gas supplier from a neighbor's phone. Follow the gas supplier's instructions.
  - If you cannot reach your gas supplier, call the fire department.
- Installation and service must be performed by a qualified installer, service agency or the gas supplier.

	<b>⚠ WARNING</b>
	Read and understand instruction manual and safety messages before installing, operating or servicing this water heater. Failure to follow instructions and safety messages could result in death or serious injury. Instruction manual must remain with water heater.

• **For Your Safety** •  
AN ODORANT IS ADDED TO THE GAS USED BY THIS WATER HEATER.

ALL TECHNICAL AND WARRANTY QUESTIONS: SHOULD BE DIRECTED TO THE LOCAL DEALER FROM WHOM THE WATER HEATER WAS PURCHASED. IF YOU ARE UNSUCCESSFUL, PLEASE CONTACT THE COMPANY LISTED ON THE RATING PLATE ON THE WATER HEATER.

KEEP THIS MANUAL IN THE POCKET ON HEATER FOR FUTURE REFERENCE  
WHENEVER MAINTENANCE ADJUSTMENT OR SERVICE IS REQUIRED.





# TABLE OF CONTENTS

Safe Installation, Use And Service . . . . .	3	Condensate . . . . .	29
General Safety . . . . .	4	Exhaust Venting . . . . .	29
Introduction . . . . .	6	Important Notes and Warnings	
Qualified Installer Or Service Agency . . . . .	6	Venting terminations and sizing	
Preparing For The Installation . . . . .	6	Vent screen installation	
Installation Requirements For The Commonwealth Of		Calculating Equivalent Feet	
Massachusetts . . . . .	7	Venting instructions	
Typical Installation . . . . .	9	Vent pipe connection to blower	
Get To Know Your Water Heater - Gas Models		Coupling installations according to vent sizes	
(List Referencing Figures 1-7) . . . . .	9	Blower Exhaust Direction . . . . .	34
Replacement Parts And Delimiting Products . . . . .	10	Vent Pipe Preparation . . . . .	34
Combo Heating Inlet And Outlet Side Taps . . . . .	10	Installation Checklist . . . . .	37
Water Piping - Mixing Valve Usage . . . . .	11	Lighting Instructions . . . . .	38
Mixing Valves		Operating The Temperature Control System . . . . .	39
Water Heater Operation . . . . .	12	Gas Control Valve/Thermostat . . . . .	40
Electrical Requirements & Wiring Diagram . . . . .	13	For Your Information . . . . .	41
Safety Lockouts . . . . .	14	Start Up Conditions . . . . .	41
High Limit Controls (Energy Cut Off) . . . . .	14	Condensate	
Thermostat/Water Temperature		Smoke/odor	
Blower High Limit Switch		Strange sounds	
Blower Air Pressure Switch . . . . .	14	Operational Conditions . . . . .	41
Flammable Vapor Sensor . . . . .	14	Smelly water	
Locating The New Water Heater . . . . .	15	“Air” In Hot-Water Faucets . . . . .	41
Facts To Consider About The Location . . . . .	15	Periodic Maintenance . . . . .	42
Storage Of Flammable Liquids . . . . .	15	General Upkeep . . . . .	42
Clearances to combustibles		Venting System Inspection . . . . .	42
Floors with carpeting		Blower Maintenance . . . . .	42
Clearance for servicing		Cleaning The Blower . . . . .	42
Insulation Blankets . . . . .	17	Burner Operation And Inspection . . . . .	43
Air Requirements . . . . .	17	Combustion Chamber And Burner Cleaning . . . . .	44
Unconfined Space . . . . .	17	Housekeeping . . . . .	44
Unusually Tight Construction . . . . .	17	Anode Rod Inspection . . . . .	44
Confined Space . . . . .	18	Anode Rod . . . . .	44
Direct Vent Appliances . . . . .	18	Removing Anode Rod:	
Exhaust Fans . . . . .	18	Installing Anode Rod:	
Fresh Air Openings For Confined Spaces . . . . .	18	Temperature-Pressure Relief Valve Test . . . . .	45
Chemical Vapor Corrosion . . . . .	19	Draining And Flushing . . . . .	46
Installing The New Water Heater . . . . .	20	To drain the water heater storage tank:	
Water Piping . . . . .	20	To flush the water heater storage tank:	
Space Heating And Potable Water Systems . . . . .	20	Leakage Checkpoints . . . . .	47
Combo Heating . . . . .	21	Service . . . . .	47
System Requirements		Reference Parts Listing . . . . .	48
Installation		Troubleshooting Guidelines . . . . .	50
Closed Water Systems . . . . .	22	Resetting The Heater Control . . . . .	53
Thermal Expansion . . . . .	22	Lockouts . . . . .	53
Temperature-Pressure Relief Valve . . . . .	23	Soft Lockout	
T&P valve discharge pipe requirements:		Hard Lockout	
Temperature-Pressure Relief Valve and		Ignition State And Timing . . . . .	53
Pipe Insulation		System Status And Error Codes . . . . .	54
High Altitude Installation . . . . .	24	Reading The LED Flash Sequence . . . . .	54
Gas Piping . . . . .	24	Notes . . . . .	58
Sediment Traps/Dirt Leg . . . . .	25		
Filling The Water Heater . . . . .	26		
Venting . . . . .	26		
Termination Clearances Sidewall Power Vent . . . . .	27		
Blower Assembly Installation . . . . .	28		
Installation Of Vent System . . . . .	28		
Planning The Vent System . . . . .	28		
Polypropylene Vent Systems . . . . .	29		

# SAFE INSTALLATION, USE AND SERVICE

Your safety and the safety of others is extremely important in the installation, use and servicing of this water heater. Many safety-related messages and instructions have been provided in this manual and on your own water heater to warn you and others of a potential injury hazard. Read and obey all safety messages and instructions throughout this manual. It is very important that the meaning of each safety message is understood by you and others who install, use or service this water heater.

	<p>This is the safety alert symbol. It is used to alert you to potential personal injury hazards. Obey all safety messages that follow this symbol to avoid possible injury or death.</p>
---	---

	<p><b>DANGER</b> indicates an imminently hazardous situation which, if not avoided, will result in death or injury.</p>
	<p><b>WARNING</b> indicates a potentially hazardous situation which, if not avoided, could result in death or injury.</p>
	<p><b>CAUTION</b> indicates a potentially hazardous situation which, if not avoided, could result in minor or moderate injury.</p>
	<p><b>CAUTION</b> used without the safety alert symbol indicates a potentially hazardous situation which, if not avoided, could result in property damage</p>

All safety messages will generally tell you about the type of hazard, what can happen if you do not follow the safety message and how to avoid the risk of injury.

The California Safe Drinking Water and Toxic Enforcement Act requires the Governor of California to publish a list of substances known to the State of California to cause cancer, birth defects or other reproductive harm and requires businesses to warn of potential exposure to such substances.

This product contains a chemical known to the State of California to cause cancer, birth defects or other reproductive harm. This appliance can cause low level exposure to some of the substances listed in the Act.

This product is certified to comply with a maximum weighted average of 0.25% lead content as required in some areas.

## IMPORTANT DEFINITIONS

**Qualified Installer:** A qualified installer must have ability equivalent to a licensed tradesman in the fields of plumbing, air supply, venting and gas supply, including a thorough understanding of the requirements of the “National Fuel Gas Code”, ANSI Z223.1/NFPA 54 as it relates to the installation of gas fired water heaters. The qualified installer must also be familiar with the design features and use of flammable vapor ignition resistant water heaters and have a thorough understanding of this Installation and Operating manual.

**Service Agency:** A service agency also must have ability equivalent to a licensed tradesman in the fields of plumbing, air supply, venting and gas supply, including a thorough understanding of the requirements of the “National Fuel Gas Code”, ANSI Z223.1/NFPA 54 as it relates to the installation of gas fired water heaters. The service agency must also have a thorough understanding of this Installation and Operating manual, and be able to perform repairs strictly in accordance with the service guidelines provided by the manufacturer.

**Gas Supplier:** The Natural Gas or Propane Utility or service who supplies gas for utilization by the gas burning appliances within this application. The gas supplier typically has responsibility for the inspection and code approval of gas piping up to and including the Natural Gas meter or Propane storage tank of a building. Many gas suppliers also offer service and inspection of appliances within the building.

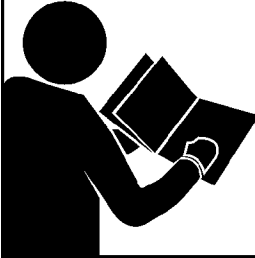

# GENERAL SAFETY

	<p><b>⚠ WARNING</b></p> <p>Read and understand instruction manual and safety messages before installing, operating or servicing this water heater.</p> <p>Failure to follow instructions and safety messages could result in death or serious injury.</p> <p>Instruction manual must remain with water heater.</p>
---	--

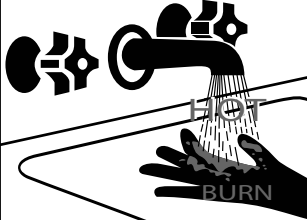
	<p><b>⚠ WARNING</b></p> <p><b>Fire Hazard</b></p> <p>For continued protection against risk of fire:</p> <ul style="list-style-type: none"> <li>• Do not install water heater on carpeted floor.</li> <li>• Do not operate water heater if flood damaged.</li> </ul>
--	---

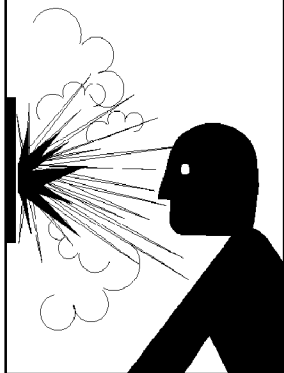
<p><b>⚠ DANGER</b></p> 	<p>Water temperature over 125°F can cause severe burns instantly resulting in severe injury or death.</p> <p>Children, the elderly and the disabled and are at highest risk of scald injury.</p> <p>Feel water before bathing or showering.</p> <p>Temperature limiting valves are available.</p> <p>Read instruction manual for safe temperature setting.</p>
--	--

	<p><b>⚠ WARNING</b></p> <p><b>Explosion Hazard</b></p> <ul style="list-style-type: none"> <li>• Overheated water can cause water tank explosion.</li> <li>• Properly sized temperature and pressure relief valve must be installed in opening provided.</li> </ul>
---	--

<p><b>⚠ WARNING</b></p> <p><b>Fire or Explosion Hazard</b></p>	
<ul style="list-style-type: none"> <li>• Do not store or use gasoline or other flammable vapors and liquids in the vicinity of this or any other appliance.</li> <li>• Avoid all ignition sources if you smell gas.</li> <li>• Do not expose water heater control to excessive gas pressure.</li> <li>• Use only gas shown on rating plate.</li> <li>• Maintain required clearances to combustibles.</li> <li>• Keep ignition sources away from faucets after extended period of non-use.</li> </ul>	
	<p>Read instruction manual before installing, using or servicing water heater.</p>
	

# GENERAL SAFETY

## CAUTION

**Improper Installation, use and service may result in property damage.**

- Do not operate water heater if flood damaged.
- Inspect anode rods regularly, replace when significantly depleted.
- Install in location with drainage.
- Fill tank with water before operation.
- Properly sized thermal expansion tanks are required on all closed water systems.

Refer to this manual for installation and service.

## ⚠ WARNING



- Before servicing the water heater, make sure the blower assembly is unplugged or the electrical supply to the water heater is turned "OFF".
- Label all wires prior to disconnection when servicing controls. Wiring error can cause improper and dangerous operation. Verify proper operation after servicing.
- Failure to do this could result in death, serious bodily injury, or property damage.

## ⚠ WARNING

**Breathing Hazard - Carbon Monoxide Gas**

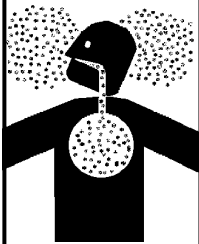

- Install vent system in accordance with codes.
- Do not operate water heater if flood damaged.
- For operation above 10,100', a high altitude orifice must be installed.
- Do not operate if soot buildup is present.
- Do not obstruct water heater air intake with insulating jacket.
- Do not obstruct blower air intake.
- Do not place chemical vapor emitting products near water heater.
- Gas and carbon monoxide detectors are available.
- No vent damper installation is compatible with this power vented water heater.

**Breathing carbon monoxide can cause brain damage or death. Always read and understand instruction manual.**

## ⚠ DANGER

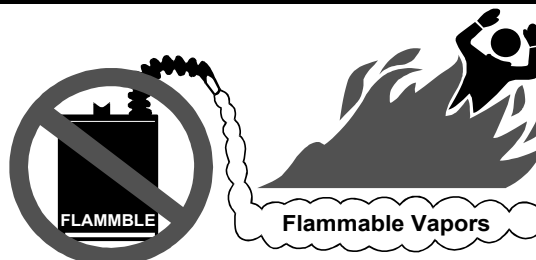

⚠ Vapors from flammable liquids may explode and catch fire causing death or severe burns.

Do not use or store flammable products such as gasoline, solvents or adhesives in the same room or area near the water heater.

Keep flammable products:

1. far away from heater,
2. in approved containers,
3. tightly closed and
4. out of children's reach.

Water heater has a main burner and hot surface igniter. The hot surface igniter:

1. can be triggered at any time and
2. the hot surface will ignite flammable vapors.

Vapors:

1. cannot be seen,
2. are heavier than air,
3. go a long way on the floor and
4. can be carried from other rooms to the the electodes by air currents.

Installation: Do not install the water heater where flammable products will be stored or used.

# INTRODUCTION

**Thank You** for purchasing this water heater. Properly installed and maintained, it should give you years of trouble free service.

Abbreviations found in this Installation and Operating manual:

- CSA - Canadian Standards Association
- ANSI - American National Standards Institute
- NFPA - National Fire Protection Association
- ASME - American Society of Mechanical Engineers
- UL - Underwriters Laboratories Inc.
- AHRI - Air Conditioning, Heating and Refrigeration Institute.

This gas-fired water heater is design certified by CSA International, under **Water Heater Standard ANSI Z21.10.3 • CSA 4.3** (current edition).

## **QUALIFIED INSTALLER OR SERVICE AGENCY**

Installation and service of this water heater requires ability equivalent to that of a Qualified Agency (as defined by ANSI below) in the field involved. Installation skills such as plumbing, air supply, venting, gas supply and electrical supply are required in addition to electrical testing skills when performing service.

**ANSI Z223.1 2006 Sec. 3.3.83:** “Qualified Agency” - “Any individual, firm, corporation or company that either in person or through a representative is engaged in and is responsible for (a) the installation, testing or replacement of gas piping or (b) the connection, installation, testing, repair or servicing of appliances and equipment; that is experienced in such work; that is familiar with all precautions required and that has complied with all the requirements of the authority having jurisdiction.”

If you are not qualified (as defined by ANSI above) and licensed or certified as required by authority having jurisdiction to perform a given task, do not attempt to perform any of the procedures described in this manual. If you do not understand the instructions given in this manual do not attempt to perform any procedures outlined in this manual.

## **PREPARING FOR THE INSTALLATION**

1. Read the “General Safety” section of this manual first and then entire manual carefully. If you don't follow safety rules, the water heater will not operate properly. It could cause DEATH, SERIOUS BODILY INJURY AND/OR PROPERTY DAMAGE. This manual contains instructions for installation, operation, and maintenance of the gas-fired water heater. It also contains warnings throughout the manual that you must read and be aware of. All warnings and instructions are essential to proper operation of the water heater and your safety. Since

we cannot put everything on the first few pages, **READ ENTIRE MANUAL BEFORE ATTEMPTING TO INSTALL OR OPERATE THE WATER HEATER.**

2. The installation must conform with these instructions and local code authority having jurisdiction. In absence of local codes, installation must comply with current editions of the “**National Fuel Gas Code**”, **ANSI Z223.1/NFPA 54** and “**National Electrical Code**”, **NFPA 70**. All documents are available from:

CSA International,  
8501 East Pleasant Valley Road,  
Cleveland, Ohio, United States  
44131-5575.

NFPA documents are also available from:  
National Fire Protection Association,  
1 Batterymarch Park,  
Quincy, MA 02269.

3. The water heater, when installed, must be electrically grounded in accordance with the local codes or in the absence of local codes, the current editions of the “**National Electrical Code**”, **NFPA 70**.
4. If after reading this manual you have any questions or do not understand any portion of the instructions, call the local gas utility or the manufacturer whose name appears on the rating plate.
5. Carefully plan the place where you are going to put the water heater. Correct combustion, vent action, and vent pipe installation are very important in preventing death from possible carbon monoxide poisoning and fires (see Figure 15 & Figure 16). Examine the location to ensure the water heater complies with the “Locating The New Water Heater” section in this manual.
6. For installation in areas subject to earthquakes, this water heater must be braced, anchored, or strapped to avoid falling or moving during an earthquake. Contact local utilities for code requirements in your area.

# INSTALLATION REQUIREMENTS FOR THE COMMONWEALTH OF MASSACHUSETTS

## COMMONWEALTH OF MASSACHUSETTS

For all side wall terminated, horizontally vented power vent, direct vent and power direct vent gas fueled water heaters installed in every dwelling, building or structure used in whole or in part for residential purposes, including those owned or operated by the Commonwealth and where the side wall exhaust vent termination is less than seven (7) feet above finished grade in the area of the venting, including but not limited to decks and porches, the following requirements shall be satisfied:

### INSTALLATION OF CARBON MONOXIDE DETECTORS

At the time of installation of the side wall horizontal vented gas fueled equipment, the installing plumber or gasfitter shall observe that a hard wired carbon monoxide detector with an alarm and battery back-up is installed on the floor level where the gas equipment is to be installed. In addition, the installing plumber or gasfitter shall observe that a battery operated or hard wired carbon monoxide detector with an alarm is installed on each additional level of the dwelling, building or structure served by the sidewall horizontal vented gas fueled equipment. It shall be the responsibility of the property owner to secure the services of qualified licensed professionals for the installation of hard wired carbon monoxide detectors. In the event that the side wall horizontally vented gas fueled equipment is installed in a crawl space or an attic, the hard wired carbon monoxide detector with alarm and battery back-up may be installed on the next adjacent floor level. In the event that the requirements of this subdivision can not be met at the time of completion of installation, the owner shall have a period of thirty (30) days to comply with the above requirements provided that during said thirty (30) day period, a battery operated carbon monoxide detector with an alarm shall be installed.

### APPROVED CARBON MONOXIDE DETECTORS

Each carbon monoxide detector as required in accordance with the above provisions shall comply with NFPA 720 and be ANSI/ UL 2034 listed and CSA certified.

### SIGNAGE

A metal or plastic identification plate shall be permanently mounted to the exterior of the building at a minimum height of eight (8) feet above grade directly in line with the exhaust vent terminal for the horizontally vented gas fueled heating appliance or equipment. The sign shall read, in print size no less than one-half (1/2) inch in size, "GAS VENT DIRECTLY BELOW. KEEP CLEAR OF ALL OBSTRUCTIONS."

### INSPECTION

The state or local gas inspector of the side wall horizontally vented gas fueled equipment shall not approve the installation unless, upon inspection, the inspector observes carbon monoxide detectors and signage installed in accordance with the provisions of 248 CMR 5.08(2)(a) 1 through 4.

### EXEMPTIONS

The following equipment is exempt from 248 CMR 5.08(2) (a) 1 through 4:

1. The equipment listed in Chapter 10 entitled "Equipment Not Required To Be Vented" in the most current edition of NFPA 54 as adopted by the Board; and
2. Product Approved side wall horizontally vented gas fueled equipment installed in a room or structure separate from the dwelling, building, or structure used in whole or in part for residential purposes.

### MANUFACTURER REQUIREMENTS - GAS EQUIPMENT VENTING SYSTEM PROVIDED

When the manufacturer of Product Approved side wall horizontally vented gas equipment provides a venting system design or venting system components with the equipment, the instructions provided by the manufacturer for installation of the equipment and the venting system shall include:

1. Detailed instructions for the installation of the venting system design or the venting system components; and
2. A complete parts list for the venting system design or venting system.

### MANUFACTURER REQUIREMENTS - GAS EQUIPMENT VENTING SYSTEM NOT PROVIDED

When the manufacturer of Product Approved side wall horizontally vented gas fueled equipment does not provide the parts for venting the flue gases, but identifies "special venting systems," the following requirements shall be satisfied by the manufacturer:

1. The referenced "special venting system" instructions shall be included with the appliance or equipment installation instructions; and
2. The "special venting systems" shall be Product Approved by the Board, and the instructions for that system shall include a parts list and detailed installation instructions.

A copy of all installation instructions for all Product Approved side wall horizontally vented gas fueled equipment, all venting instructions, all parts lists for venting instructions, and/or all venting design instructions shall remain with the appliance or equipment at the completion of the installation.

# INSTALLATION GRAPHIC: GAS-FIRED POTABLE WATER HEATING/SPACE HEATING SYSTEM

- If your water heater will be installed in the Commonwealth of Massachusetts, refer to the following graphic during installation and during modifications to the water supply system.

TYPICAL MIXING VALVE INSTALLATION  
COMBINATION SPACE HEATING / POTABLE WATER HEATING SYSTEM

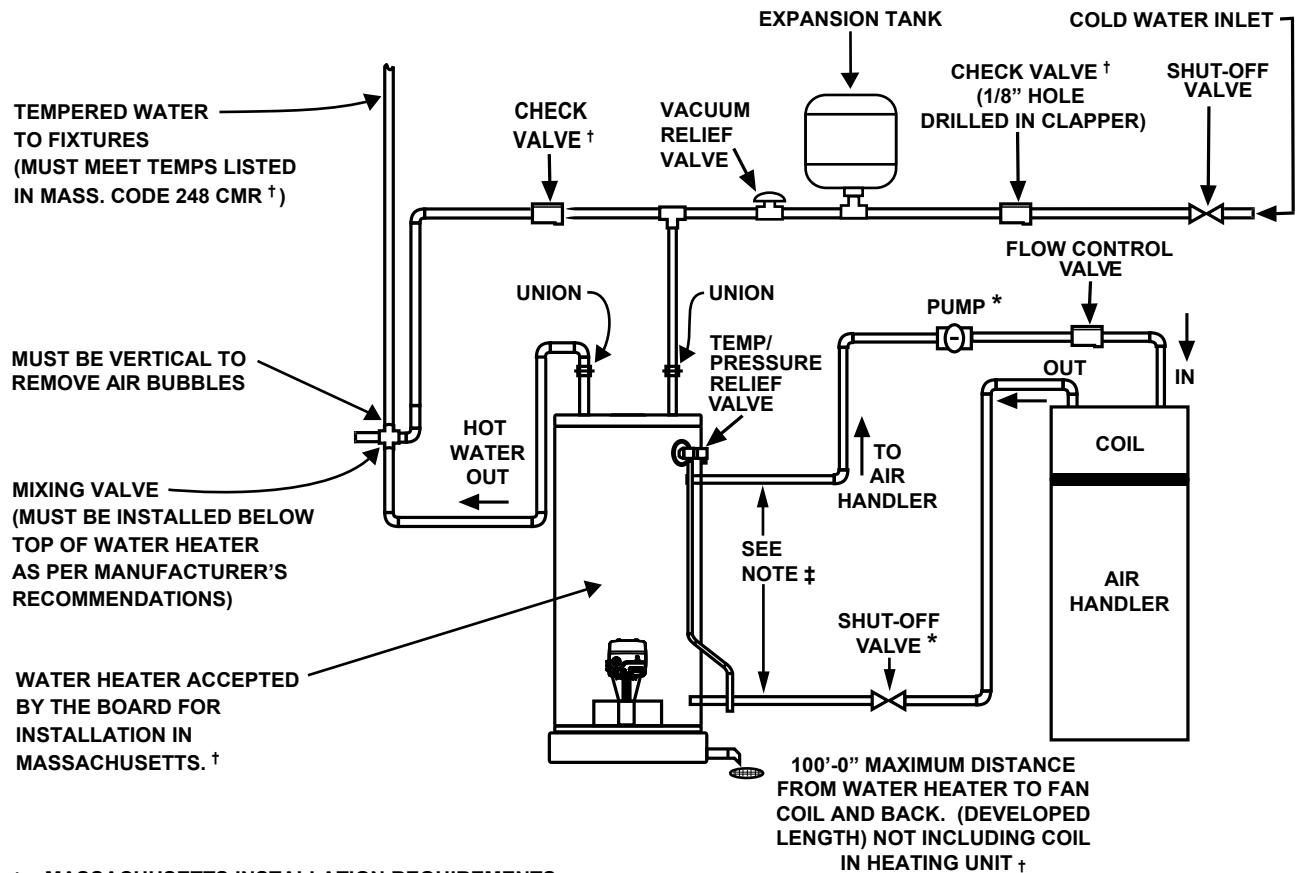

\* MASSACHUSETTS INSTALLATION REQUIREMENTS:

- 1.) CONNECT ELECTRONICALLY-CONTROLLED TIMER TO AN ALL-BRONZE PUMP. PUMP MUST ACTIVATE EVERY 6 HOURS FOR 60 SECONDS. TURN PUMP TIMER OFF BEFORE CLOSING PIPING LOOP SHUT-OFF VALVE.
- 2.) ALL WATER PIPING MUST BE INSTALLED AND INSULATED IN ACCORDANCE WITH MASSACHUSETTS CODE (248 CMR & 780 CMR).
- 3.) PIPING LOOP BETWEEN WATER HEATER AND AIR HANDLER MUST BE INSTALLED IN COMPLIANCE WITH 248 CMR.

† REQUIRED FOR MASSACHUSETTS.

‡ PIPING FROM THE TOP OF THE WATER HEATER WITH TEES IS ACCEPTABLE.



# TYPICAL INSTALLATION

## GET TO KNOW YOUR WATER HEATER - GAS MODELS (LIST REFERENCING FIGURES 1-7)

- |  |  |  |
|--|--|--|
| 1 Vent Termination Elbow with Rodent Screen                  | 17 Manifold Door Assembly (behind outer door) (see Figure 3 (NG) or Figure 4 (LP)) | 36 *Thermal Expansion Tank (required for all closed systems) |
| 2 *Vent Pipe   | 18 *Floor Drain  | 37 Aluminum Burner (see Figure 3)                            |
| 3 *Vent Pipe Coupling (if required)                          | 19 *Metal Drain Pan  | 38 Gas Orifice (see Figure 3)                                |
| 4 CPVC Vent Pipe (5 ft. supplied)                            | 20 Flammable Vapor Sensor (under cover) (see Figure 5)                             | 39 Gas Manifold (see Figure 3)                               |
| 5 *CPVC Vent Pipe Elbow (long radius)                        | 21 Flexible Manifold Tube (see Figure 3)   | 40 Hot-Surface Igniter (see Figure 3)                        |
| 6 Gear Clamp (see Figure 6)                                  | 22 *Sediment Trap/Dirt Leg   | 41 Manifold Door Gasket (see Figure 3)                       |
| 7 T&P Valve  | 23 *Ground Joint Union (gas connection)  | 42 Manifold Door (see Figure 3)                              |
| 8 **Combo Heating System Supply Outlet (Optional)            | 24 *Main Manual Gas Shut-off Valve   | 43 Two Piece Grommet With Clip (see Figure 3)                |
| 9 Cold-Water Inlet Nipple/Diptube                            | 25 *Gas Supply*  | 44 Viewport (see Figure 3)                                   |
| 10 * Discharge Pipe  | 26 Baffle Assembly   | 45 Flame Sensor Rod (see Figure 3)                           |
| 11 Gas Control Valve/Thermostat (Honeywell)                  | 27 Rating Plate  | 46 Stainless Steel Burner (see Figure 4)                     |
| 12 Gas Valve Electronic Control Module And Cover (Honeywell) | 28 Blower with Power Cord (see Figure 6)   | 47 Air Switch (inside box) (see Figure 6)                    |
| 13 **Combo Heating System Return Inlet (Optional)            | 29 *Rubber Coupling (see Figure 6)   | 48 Air Tubing (see Figure 6)                                 |
| 14 ***Control Harness  | 30 *Inlet Water Shut-off Valve   | 49 Blower High Limit Switch (see Figure 6)                   |
| 15 Drain Valve   | 31 *Union (water connection)   | 50 Junction Box Cover (see Figure 6)                         |
| 16 Outer Gas Door  | 32 Hot-Water Outlet Nipple   | 51 Junction Box (see Figure 6)                               |
|  | 33 Anode (under cap)   |  |
|  | 34 Air Inlet Snorkel   |  |
|  | 35 Flue Collector  |  |
- \*, \*\*, \*\*\*, \*\*\*\* see notes on following page

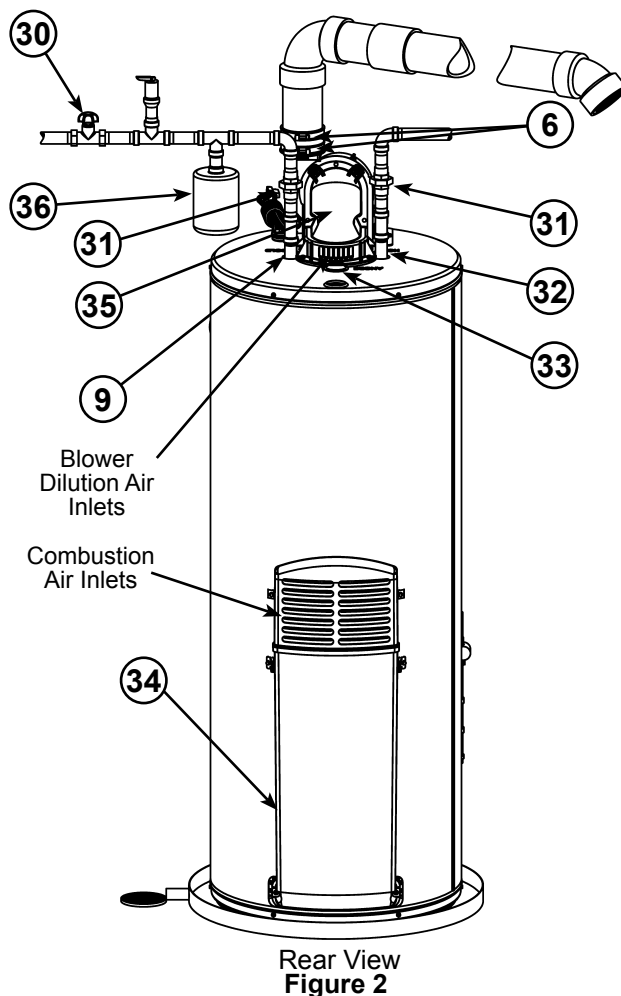
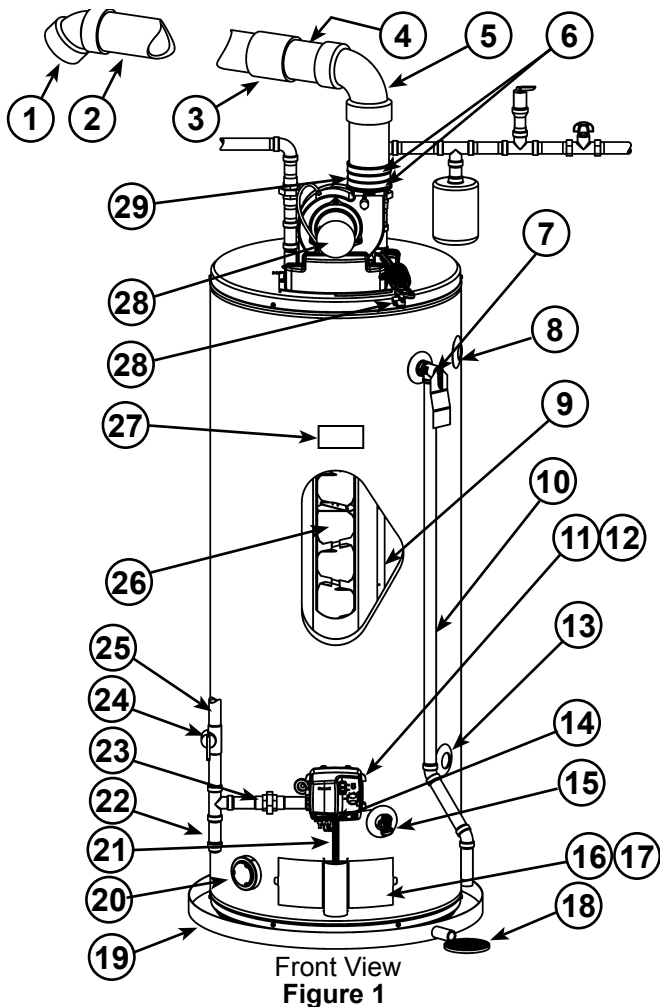

Natural gas main burner with igniter assembly (item 17 in Figure 1).

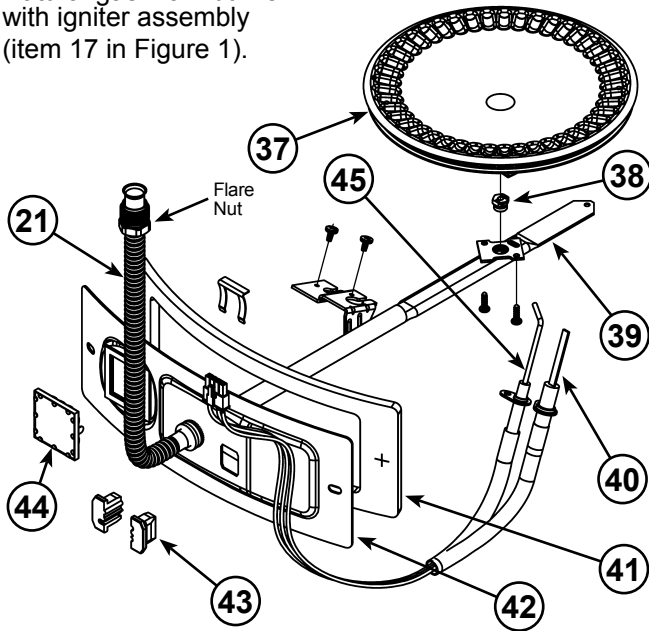

Figure 3

Propane (LP) main burner with igniter assembly (item 17 in Figure 1).

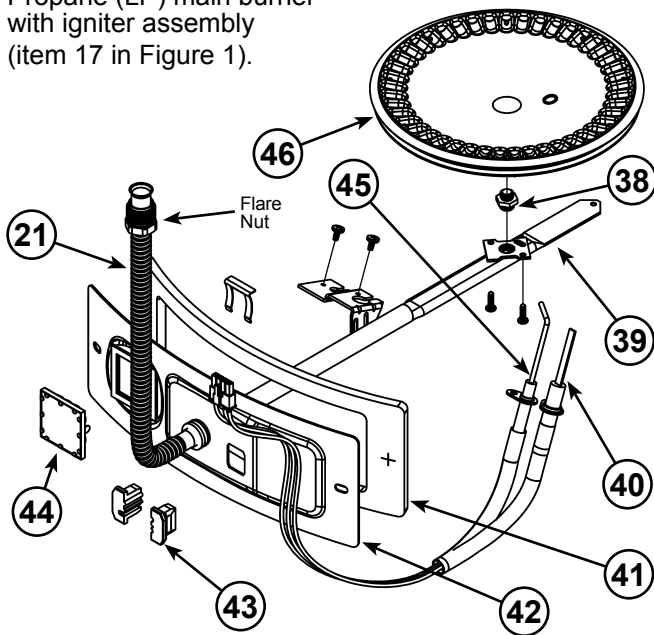

Figure 4

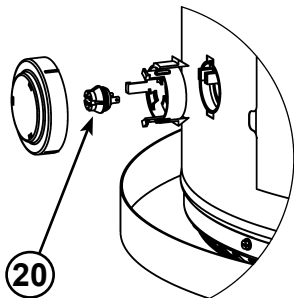

Figure 5

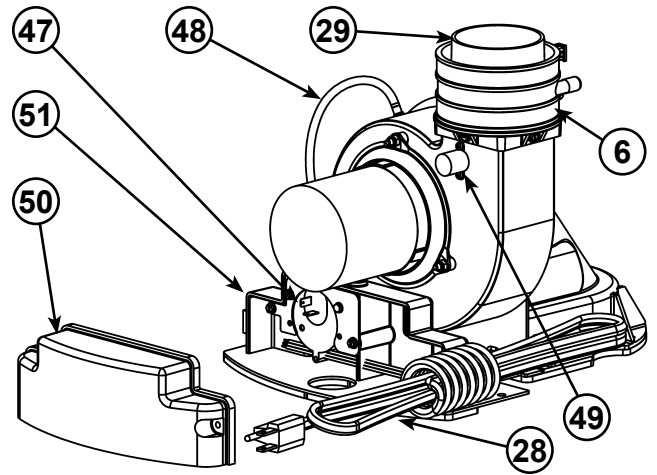

Figure 6

Vacuum relief valve install per local codes (not supplied with heater).

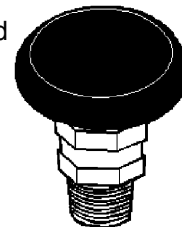

Figure 7

**Notes:**

- \* Items not supplied with the water heater.
- \*\* The side recirculation loop connections may not be used as the primary water inlet and outlet connections. See "Combo Heating Inlet And Outlet Side Taps".
- \*\*\* **Caution:** harness has 120 VAC in operation.
- \*\*\*\* See "Planning The Vent System", "Condensate" and "Blower Assembly Installation" for more information.

**REPLACEMENT PARTS AND DELIMING PRODUCTS**

Replacement parts and recommended delimer may be ordered through authorized servicers or distributors. When ordering parts, provide complete model and serial numbers (see rating plate), quantity and name of part desired. Standard hardware items may be purchased locally.

**COMBO HEATING INLET AND OUTLET SIDE TAPS**

Models equipped with Combo Heating capabilities are shipped with the two side plumbing taps **OPEN** (item 8 and item 13 in Figure 1 and see also Figure 8 & Figure 28). If the heater is to be operated without using the side taps these openings **must be plugged** with the two pipe plugs supplied with the heaters.

# WATER PIPING - MIXING VALVE USAGE

## Mixing Valves

▲ DANGER

**Water temperature over 125°F can cause severe burns instantly resulting in severe injury or death.**

**Children, the elderly and the disabled and are at highest risk of scald injury.**

**Feel water before bathing or showering.**

**Temperature limiting devices such as mixing valves must be installed when required by codes and to ensure safe temperatures at fixtures.**

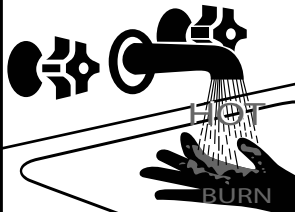

Water heated to a temperature which satisfies space heating, clothes washing, dish washing, and other sanitizing needs can scald and cause permanent injury upon contact. Short repeated heating cycles caused by small hot-water uses can cause a temperature increase of the hot water by 20F° higher than the heater's temperature settings.

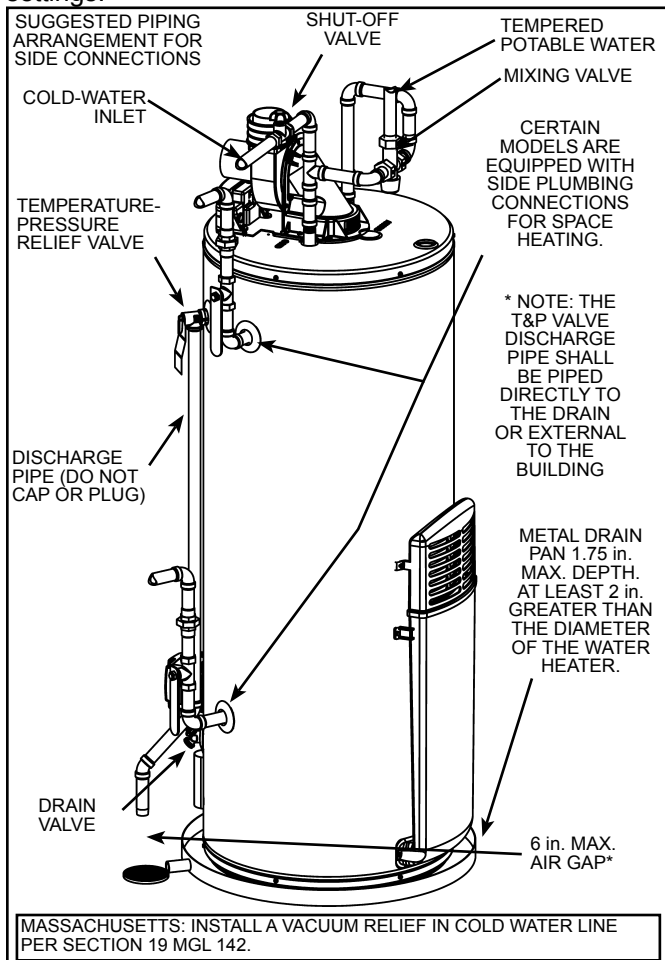

Figure 8

This appliance has been design certified as complying with American National Standard/CSA Standard for water heaters and certain models with side plumbing connections are considered suitable for Water (Potable) Heating and Space Heating. **Note:** Do not use in space heating only applications.

The water supply pressure should not exceed 80 psi. If this occurs, a pressure reducing valve with a bypass should be installed in the cold water inlet line. This should be placed on the supply to the entire house in order to maintain equal hot and cold water pressures.

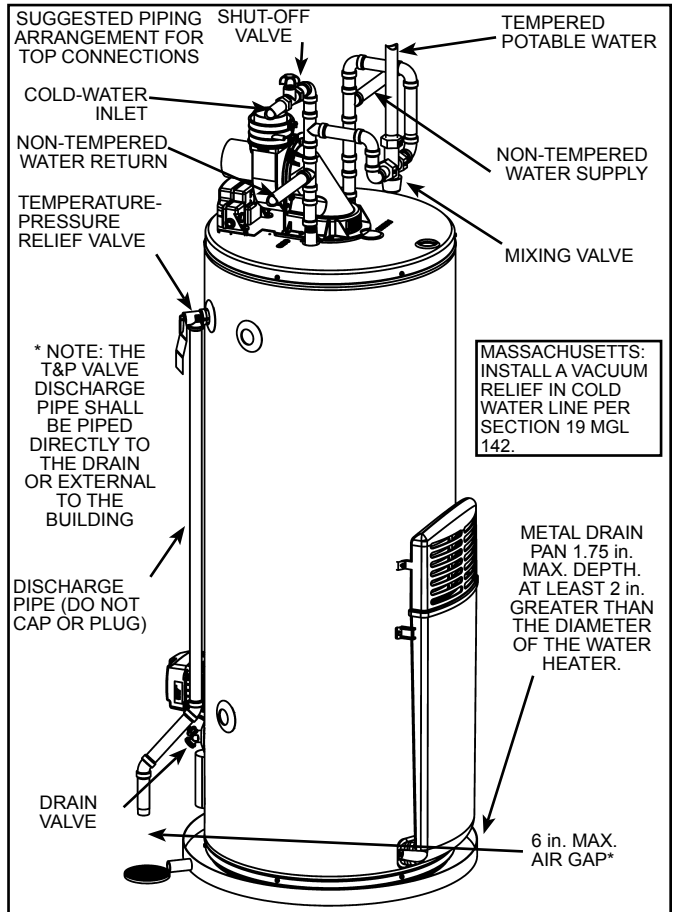

Figure 9

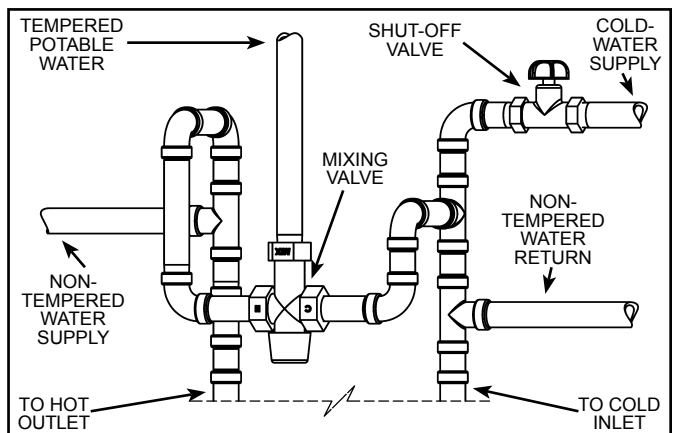

Figure 10

Some people are more likely to be permanently injured by hot water than others. These include the elderly, children, the infirm and the physically/mentally disabled. Table 1 (published by U.S. Government Memorandum, 1978) shows the approximate time-to-burn relationship for normal adult skin. If anyone using hot water provided by the water heater being installed fits into one of these groups or if there is a local code or state law requiring a certain water temperature at the point of use, then special precautions must be taken.

Water Temperature °F	Time for 1st Degree Burns (Less Severe Burns)	Time for Permanent Burns 2nd & 3rd Degree (Most Severe Burns)
110	(normal shower temp.)	
116	(pain threshold)	
116	35 minutes	45 minutes
122	1 minute	5 minutes
131	5 seconds	25 seconds
140	2 seconds	5 seconds
149	1 second	2 seconds
154	instantaneous	1 seconds

(U.S. Government Memorandum, C.P.S.C., Peter L. Armstrong, Sept. 15, 1978)

**Table 1**

In addition to using lowest possible temperature setting that satisfies demand of application, a mixing valve should be installed at water heater (see Figure 8 & Figure 9) or at hot-water taps to further reduce system water temperature. Mixing valves are available at plumbing supply stores. Consult a Qualified Installer or Service Agency. Follow mixing valve manufacturer’s instructions for installation of the valves. Before changing the factory setting on the thermostat, read the “Operating The Temperature Control System” section in this manual.

## WATER HEATER OPERATION

Figure 11 shows the water heater’s sequence of operation when a call for heat is initiated. The ignition control module will attempt to light the burner three times. If the ignition control does not detect ignition it will enter lockout mode and flash the corresponding error code.

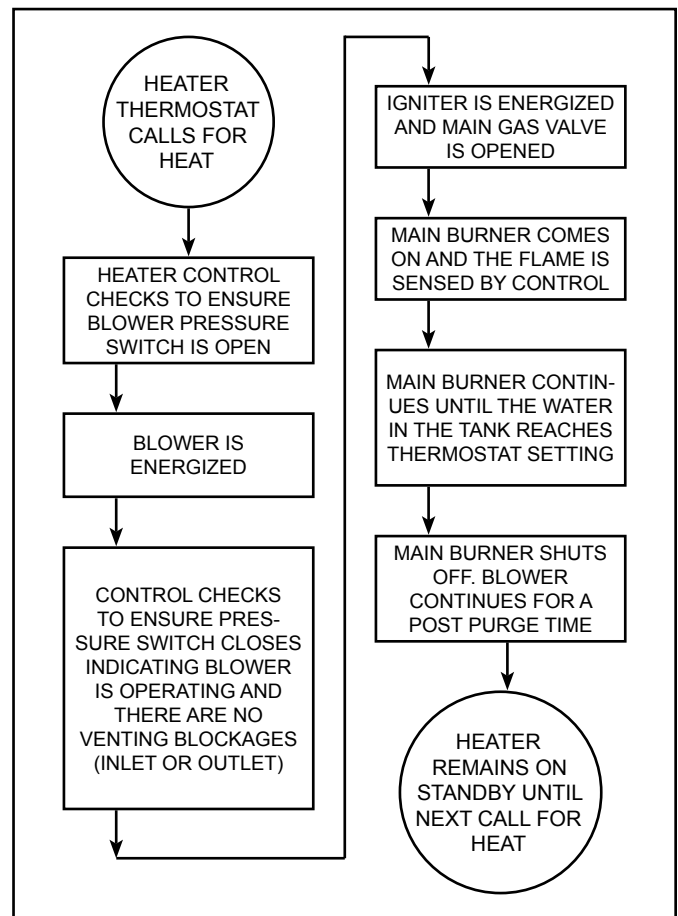

**Figure 11**

## ELECTRICAL REQUIREMENTS & WIRING DIAGRAM

⚠ WARNING



Electric Shock Hazard

Disconnect power before servicing.

Replace all parts and panels before operating.

Failure to do so can result in death or electrical shock.

Before plugging in the water heater, always make sure:

- The voltage and frequency correspond to that specified on the water heater wiring diagram.
  - The electrical outlet has the proper overload fuse or breaker protection.
1. The unit must be connected to a dedicated power supply.
  2. The unit must be connected to a 120VAC power supply.
  3. The water heater must be properly grounded.
  4. This water heater is a polarity sensitive appliance and will not operate if the power supply polarity is reversed.

**Note:** Always reference the wiring diagram for the correct electrical connections.

After making all electrical connections, completely fill the tank with water and check all connections for leaks. Open the nearest hot-water faucet and let it run for 3 minutes to purge the water lines of air and sediment and to ensure complete filling of the tank. The electrical power may then be turned on. Verify proper operation after servicing. See also “Installation Checklist”.

## CAUTION

LABEL ALL WIRES PRIOR TO DISCONNECTION WHEN SERVICING CONTROLS. WIRING ERRORS CAN CAUSE IMPROPER AND DANGEROUS OPERATION. VERIFY PROPER OPERATION AFTER SERVICING. POWER VENT WIRING SCHEMATIC.

**NOTE: REFER TO THE “Installation Checklist” BEFORE OPERATING THIS HEATER.**

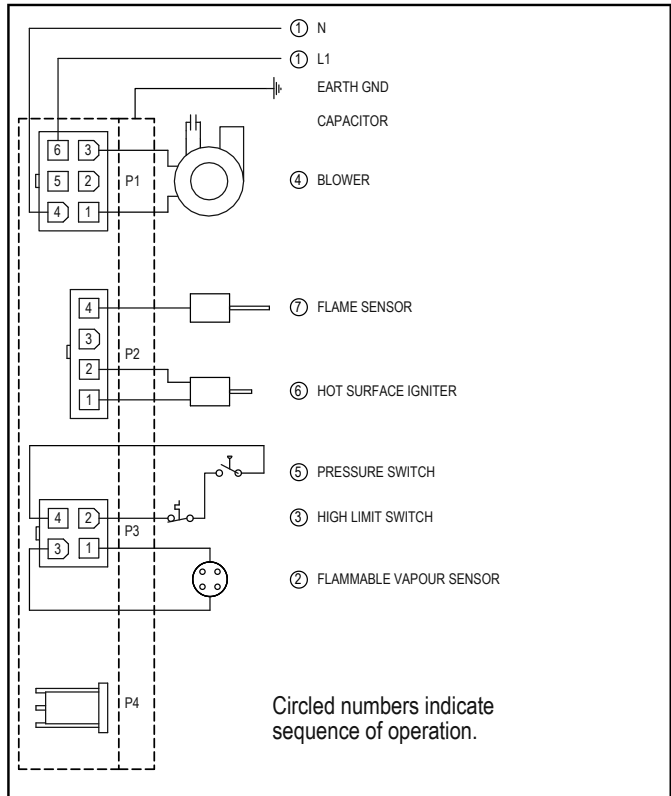

**Figure 13**

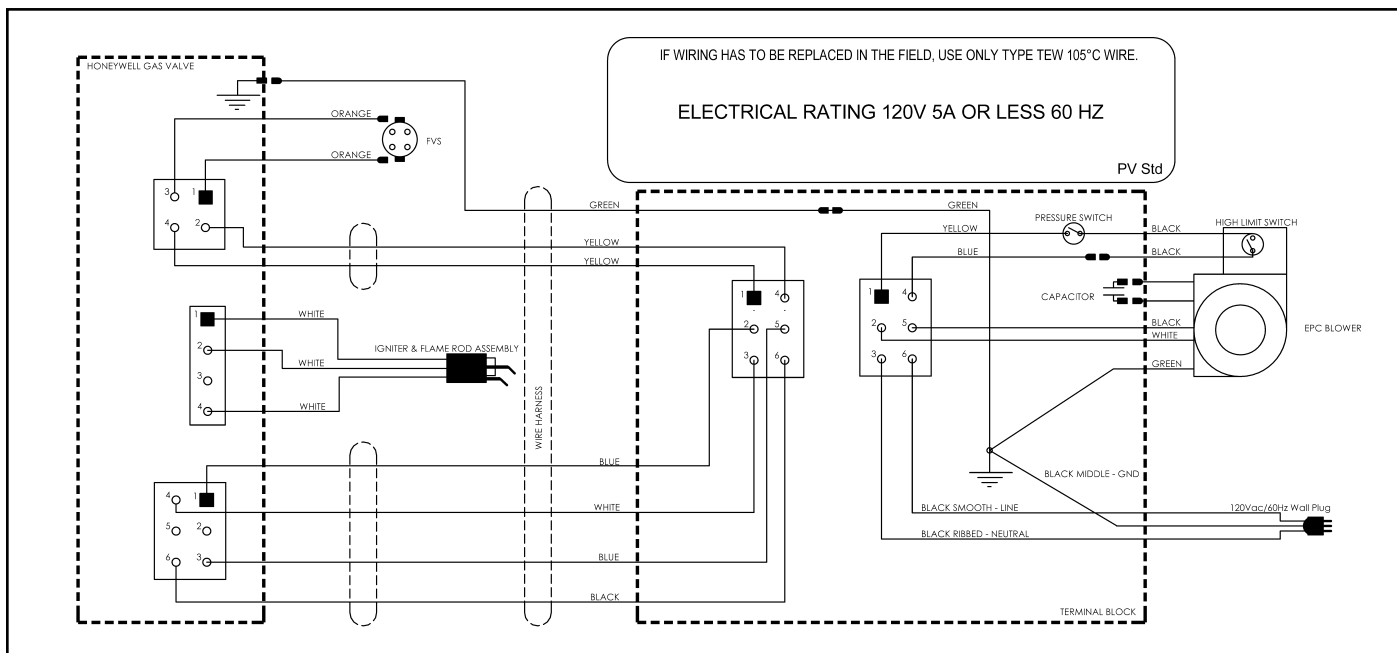

**Figure 12**

# SAFETY LOCKOUTS

This water heater has several lockout features designed to prevent the heater from operating in unsafe conditions.

## HIGH LIMIT CONTROLS (ENERGY CUT OFF)

### **Thermostat/Water Temperature**

This feature is a part of the gas control valve/thermostat (see Figure 1, item 11) and limits the maximum water temperature. In the event of the water overheating, this safety feature shuts off the fuel supply to the burner. This ECO is not resettable and the gas control valve/thermostat will need to be replaced by a qualified service technician.

### **Blower High Limit Switch**

This device is located on the blower (see Figure 6, item 49) and limits the maximum temperature of the blower. If the blower temperature rises above the temperature setting, the switch opens causing the heater to shut down. The switch will auto reset once the temperature drops sufficiently.

## BLOWER AIR PRESSURE SWITCH

This device, located in the junction box, monitors the air pressure produced by the blower. In the event that the exhaust venting becomes blocked or sufficiently restricted, the switch will shut the heater down (see Figure 6, item 47). If the water heater has not gone into a soft lockout condition, the heater will restart after the blockage is removed (see “Resetting The Heater Control”).

## FLAMMABLE VAPOR SENSOR

When using a gas fired water heater there is a risk of flammable vapors entering the combustion chamber, being ignited by the burner flame and causing a flashback. In order to detect such flammable vapors before they enter the combustion chamber, this water heater is equipped with a flammable vapor sensor (FVS). It is a chemical-absorption based sensor that is connected to the gas control/thermostat (see Figure 14). When exposed to flammable vapors it will trigger the control to stop the flow of gas and enter the FVS lockout state. While in the FVS lockout state the LED on the control will flash the gas lockout code. (Refer to the “System Status And Error Codes” section of this manual for an explanation of the codes applicable to the control installed on your water heater.) If this error occurs, check around the water heater for sources of chemical contamination such as: flammable vapors including gas vapors, solvents, paint and thinners as well as sources of water and detergents.

**Note:** Resetting the heater will reset the FVIR circuit if all sources of contamination have been removed and the sensor clears. If all sources of contamination have been removed and the system will not reset, the sensor will need to be replaced (see “Resetting The Heater Control”).

If there is a problem with the wiring of the flammable vapor sensor or the flammable vapor interface, the LED will flash the failure status code (see “System Status And Error Codes”).

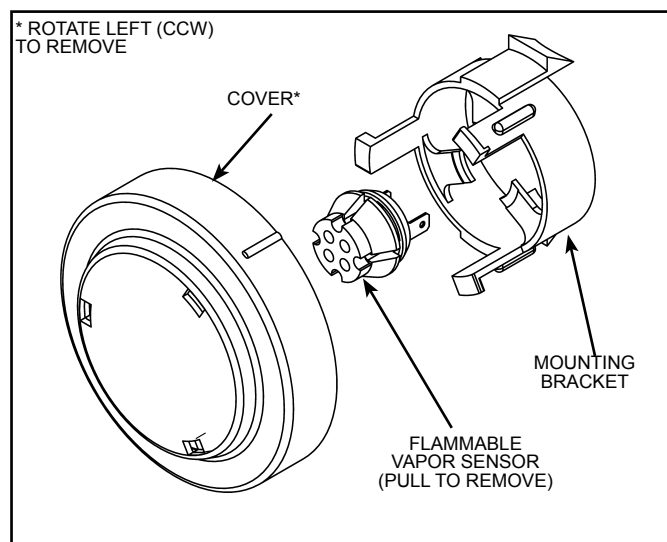

Figure 14

# LOCATING THE NEW WATER HEATER

## FACTS TO CONSIDER ABOUT THE LOCATION

Carefully choose an indoor location for the new water heater because the placement is a very important consideration for the safety of the occupants in the building and for the most economical use of the appliance. This water heater is not for use in manufactured (mobile) homes or outdoor installation.

Whether replacing an old water heater or putting the water heater in a new location, the following critical points must be observed:

1. Select a location indoors as close as practical to the vent termination or location to which the water heater vent piping is going to be connected, and as centralized with the water piping system as possible.
2. Selected location must provide adequate clearances for servicing and proper operation of the water heater.
3. Ensure the area has a continuous supply of air for combustion, dilution and ventilation.
4. Avoid locations that could cause the water heater to freeze from outside air.
5. Selected location must provide access to a properly grounded electrical branch circuit. A dedicated circuit is preferred. Do not use a GFI outlet.
6. Avoid locations that expose the water heater to direct sunlight.
7. Keep combustibles such as boxes, magazines, clothes, etc., away from the water heater area.

**Important:** Do not use an extension cord to connect the water heater to an electrical outlet.

**Important:** this heater has special venting requirements when installed in areas where the ambient temperatures exceed 110°F (see “Polypropylene Vent Systems”).

## CAUTION

### Property Damage Hazard

- All water heaters eventually leak.
- Do not install without adequate drainage.

Installation of the water heater must be accomplished in such a manner that if the tank or any connections should leak, the flow of water will not cause damage to the structure. For this reason it is not advisable to install the water heater in an attic or upper floor. In all cases, a metal drain pan should be installed under the water heater. Metal drain pans are available at your local hardware store. Such a metal drain pan must have a clearance of at least 1 in. greater than any point on the water heater’s outer jacket and must be piped to an adequate drain. The pan must have a maximum depth of 1.75 in..

Water heater life depends upon water quality, water pressure and the environment in which the water heater is installed. Water heaters are sometimes installed in locations where leakage may result in property damage, even with the use of a metal drain pan piped to a drain.

However, unanticipated damage can be reduced or prevented by a leak detector or water shut-off device used in conjunction with a piped metal drain pan. These devices are available from some plumbing supply wholesalers and retailers, and detect and react to leakage in various ways:

- Sensors mounted in the metal drain pan that trigger an alarm or turn off the incoming water to the water heater when leakage is detected.
- Sensors mounted in the metal drain pan that turn off the water supply to the entire building when water is detected in the metal drain pan.
- Water supply shut-off devices that activate based on the water pressure differential between the cold-water and hot-water pipes connected to the water heater.
- Devices that will turn off the gas supply to a gas water heater while at the same time shutting off its water supply.

## STORAGE OF FLAMMABLE LIQUIDS

Flammable liquids (such as gasoline, solvents, propane (LP or butane, etc.) and other substances (such as adhesives, paints, etc.) emit flammable vapors which can be ignited by a gas water heater’s hot surface igniter (HSI) or main burner. The resulting flashback and fire can cause death or serious burns to anyone in the area.

This water heater is equipped with a FV (Flammable Vapor) sensor for detecting the presence of flammable vapors. When the sensor detects those vapors, the unit will shut down and not operate. Should this happen, please refer to the “Troubleshooting Guidelines” section of this manual. Even though this water heater is a flammable vapors ignition resistant (FVIR) water heater and is designed to reduce the chances of flammable vapors being ignited, gasoline and other flammable substances should never be stored or used in the same vicinity or area containing a gas water heater or other open flame or spark producing appliance. Examples of such locations are garages, storage and utility areas.

The water heater must be located and/or protected so it is not subject to physical damage by a moving vehicle.

**⚠ WARNING**

**Fire or Explosion Hazard**

- Do not store or use gasoline or other flammable vapors and liquids in the vicinity of this or any other appliance.
- Avoid all ignition sources if you smell gas.
- Do not expose water heater control to excessive gas pressure.
- Use only gas shown on rating plate.
- Maintain required clearances to combustibles.
- Keep ignition sources away from faucets after extended period of non-use.

**Read instruction manual before installing, using or servicing water heater.**

**⚠ WARNING**

**FIRE AND EXPLOSION HAZARD**  
Can result in serious injury or death

Do not store or use gasoline or other flammable vapors and liquids in the vicinity of this or any other appliance. Storage or use of gasoline or other flammable vapors or liquids in the vicinity of this or any other appliance can result in serious injury or death.

**⚠ WARNING**

**Fire Hazard**

For continued protection against risk of fire:

- Do not install water heater on carpeted floor.
- Do not operate water heater if flood damaged.

**Clearances to combustibles**

Minimum clearances between water heater and combustibles are 0 in. at the sides and rear, 5.5 in. from the front and 12 in. from top (standard clearance.) If clearances stated on the heater differ from standard clearances, install water heater according to clearances stated on the heater (see Figure 15).

**Floors with carpeting**

This water heater must not be installed directly on carpeting. Carpeting must be protected by a metal or wood panel beneath the appliance extending beyond the full width and depth of the appliance by at least 76mm (3 in. in every direction, or if the appliance is installed in an alcove or closet, the entire floor must be covered by the panel. Failure to heed this warning may result in a fire hazard.

**Clearance for servicing**

Adequate clearance of 24 in. for servicing this appliance should be considered before installation, such as changing the anodes, etc.

A minimum clearance of 5.5 in. must be allowed for access to replaceable parts such as thermostats, drain valve and relief valve.

When installing the heater, consideration must be given to proper location. Location selected should be as close to the wall as practicable and as centralized with the water piping system as possible.

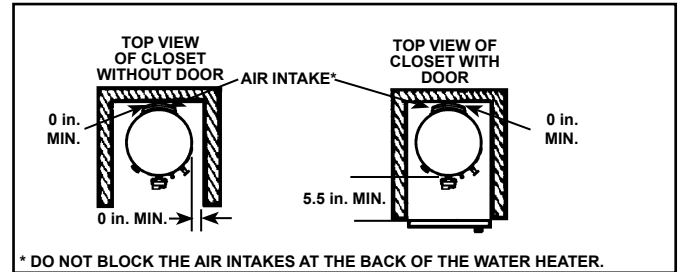

**Figure 15**

A gas water heater cannot operate properly without the correct amount of air for combustion and ventilation. Do not install in a confined area such as a closet unless you provide air as shown below and described in the "Air Requirements" section (see Figure 16). Never obstruct the flow of ventilation air for dilution and combustion. If you have any doubts or questions at all, call your gas supplier. Failure to provide the proper amount of combustion air can result in a fire or explosion and cause death, serious bodily injury, or property damage.

**⚠ WARNING**

**Breathing Hazard - Carbon Monoxide Gas**

- Install water heater in accordance with the instruction manual and NFPA 54.
- To avoid injury, combustion and ventilation air must be taken from outdoors.
- Do not place chemical vapor emitting products near water heater.

**Breathing carbon monoxide can cause brain damage or death. Always read and understand instruction manual.**

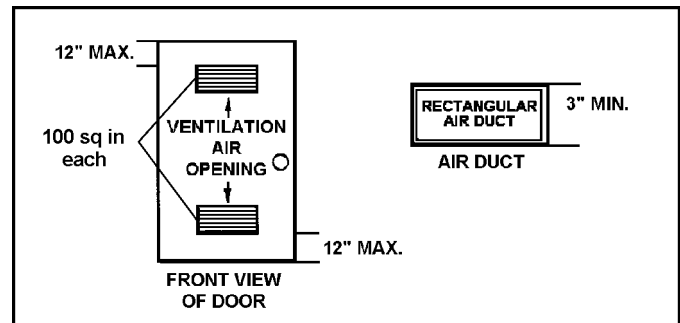

**Figure 16**

If this water heater will be used in beauty shops, barber



shops, cleaning establishments, or self-service laundries with dry cleaning equipment, it is imperative that the water heater or water heaters be installed so that combustion and ventilation air be taken from outside these areas. Propellants of aerosol sprays and volatile compounds, (cleaners, chlorine based chemicals, refrigerants, etc.) in addition to being highly flammable in many cases, will also react to form corrosive hydrochloric acid when exposed to the combustion products of the water heater. The results can be hazardous, and also cause product failure.

## INSULATION BLANKETS

Insulation blankets are available to the general public for external use on gas water heaters but are not necessary with these products. The purpose of an insulation blanket is to reduce standby heat loss encountered with storage tank heaters. Your water heater meets or exceeds the current standards with respect to insulation and standby loss requirements, making an insulation blanket unnecessary. Should you choose to apply an insulation blanket to this heater, you should follow these instructions (For identification of components mentioned below, see Figure 1 thru Figure 7). Failure to follow these instructions will restrict the air flow required for proper combustion and dilution, potentially resulting in fire, asphyxiation, serious personal injury or death.

- Do not apply insulation to the top of the water heater, as this will interfere with safe operation of the blower assembly.
- Do not cover the outer door, thermostat or T&P relief valve, FV sensor, or Air Intake Snorkel.
- Do not cover the "Installation And Operating manual". Keep it on the side of the water heater or nearby for future reference.
- Do obtain new warning and instruction labels from the manufacturer for placement on the blanket directly over the existing labels.
- Do inspect the insulation blanket frequently to make certain it does not sag, thereby obstructing combustion air flow.

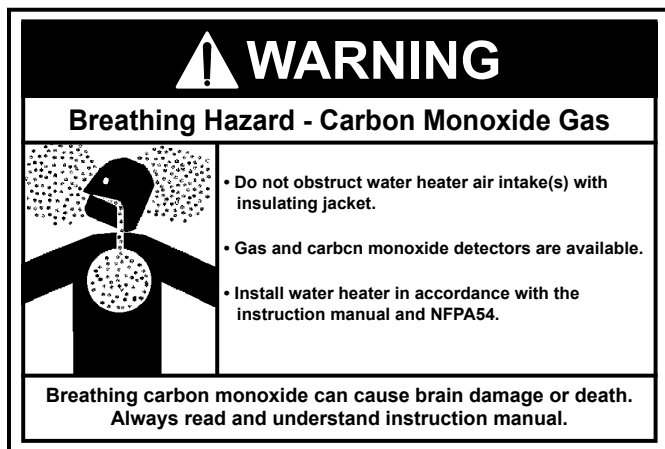

## AIR REQUIREMENTS

For safe operation an adequate supply of fresh, uncontaminated air for combustion, dilution and ventilation must be provided.

**Note:** Contaminated or dusty air may cause build-up on the blower wheel resulting in nuisance shut downs.

An insufficient supply of air can cause recirculation of combustion products resulting in contamination that may be hazardous to life. Such a condition often will result in a yellow, luminous burner flame, causing sooting of the combustion chamber, burners and flue tubes and creates a risk of asphyxiation.

Do not install the water heater in a confined space unless an adequate supply of air for combustion, dilution and ventilation is brought into that space using the methods described in the "Confined Space" section that follows.

Never obstruct the flow of dilution/ventilation air. If you have any doubts or questions at all, call your gas supplier. Failure to provide the proper amounts of air can result in a fire or explosion and cause property damage, serious bodily injury or death. The combustion and dilution air inlets are shown in Figure 2.

**Important:** Power Vented water heaters require air for combustion and dilution air for the blower.

Air supply must be provided as required by the current edition of "**Natural Gas and Propane Installation Codes**" **B149.1**.

## UNCONFINED SPACE

An Unconfined Space is one whose volume is not less than 50 cubic feet per 1,000 Btu/hr of the total input rating of all appliances installed in the space. Rooms communicating directly with the space in which the appliances are installed, through openings not furnished with doors, are considered a part of the unconfined space.

Makeup air requirements for the operation of exhaust fans, kitchen ventilation systems, clothes dryers and fireplaces should also be considered in determining the adequacy of a space to provide combustion, ventilation and dilution air.

## UNUSUALLY TIGHT CONSTRUCTION

In unconfined spaces in buildings, infiltration may be adequate to provide air for combustion, ventilation and dilution of flue gases. However, in buildings of unusually tight construction (e.g., weather stripping, heavily insulated, caulked, vapour/vapor barrier, etc.) additional air must be provided using the methods described in the "Confined Space" section that follows.

## CONFINED SPACE

A Confined Space is one whose volume is less than 50 cubic feet per 1,000 Btu/hr of the total input rating of all appliances installed in the space.

Openings must be installed to provide fresh air for combustion, ventilation and dilution in confined spaces. The required size for the openings is dependent on the method used to provide fresh air to the confined space and the total Btu/hr input rating of all appliances installed in the space.

## DIRECT VENT APPLIANCES

Other appliances installed in a Direct Vent configuration that derive all air for combustion from the outdoor atmosphere through sealed intake air piping are not factored in the total appliance input Btu/hr calculations used to determine the size of openings providing fresh air into confined spaces.

## EXHAUST FANS

Where exhaust fans are installed, additional air should be provided to replace the exhausted air. When an exhaust fan is installed in the same space with a water heater, sufficient openings to provide fresh air must be provided that accommodate the requirements for all appliances in the room and the exhaust fan. Undersized openings will cause air to be drawn into the room through the water heater's vent system causing poor combustion. Sooting, serious damage to the water heater and the risk of fire or explosion may result. It can also create a risk of asphyxiation.

## FRESH AIR OPENINGS FOR CONFINED SPACES

The following instructions should be used to calculate the size, number and placement of openings providing fresh air for combustion, ventilation and dilution in confined spaces. The illustrations shown in this section of the manual are a reference for the openings that provide fresh air into confined spaces only. Do not refer to these illustrations for the purpose of vent installation. See "Installation Of Vent System" section for complete venting installation instructions.

Chemical vapourvapor corrosion of the flue, blower assembly and vent system may occur if the air supply contains certain chemical vapoursvapors. Spray can propellants, cleaning solvents, refrigerator and air conditioner refrigerants, swimming pool chemicals, calcium and sodium chloride (water softener salt), waxes, bleach and process chemicals are typical compounds which are potentially corrosive.

### A. ALL AIR FROM INSIDE BUILDINGS: (See Figure 17)

The confined space shall be provided with two permanent openings communicating directly with an additional room(s) of sufficient volume so that the combined volume of all spaces meets the criteria for an unconfined space. The total input of all gas utilization equipment installed in the combined space shall be

considered in making this determination. Each opening shall have a minimum free area of one square inch per 1,000 Btu/hr of the total input rating of all gas utilization equipment in the confined space, but not less than 100 square inches. One opening shall commence within 305mm (12 in.) of the top and one commencing within 305mm (12 in.) of the bottom of the enclosures.

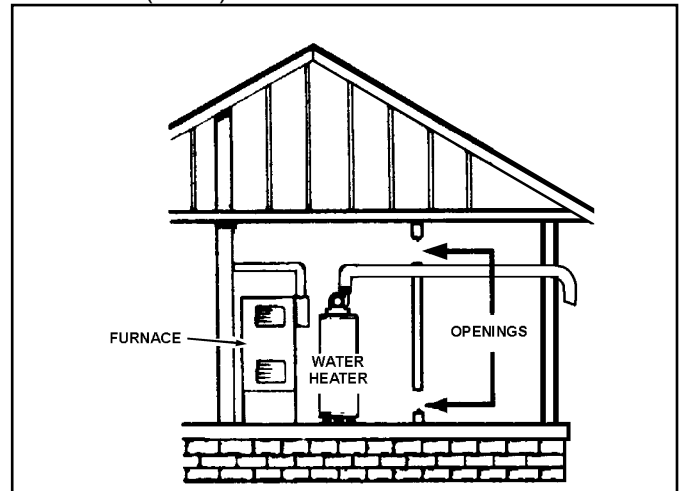

Figure 17

### B. ALL AIR FROM OUTDOORS: (See Figure 18 thru Figure 20)

The confined space shall be provided with two permanent openings, one commencing within 305mm (12 in.) of the top and one commencing within 305mm (12 in.) from the bottom of the enclosure. The openings shall communicate directly, or by ducts, with the outdoors or spaces (crawl or attic) that freely communicate with the outdoors.

1. When directly communicating with the outdoors, each opening shall have a minimum free area of 1 square inch per 4,000 Btu/hr of total input rating of all equipment in the enclosure (see Figure 18).

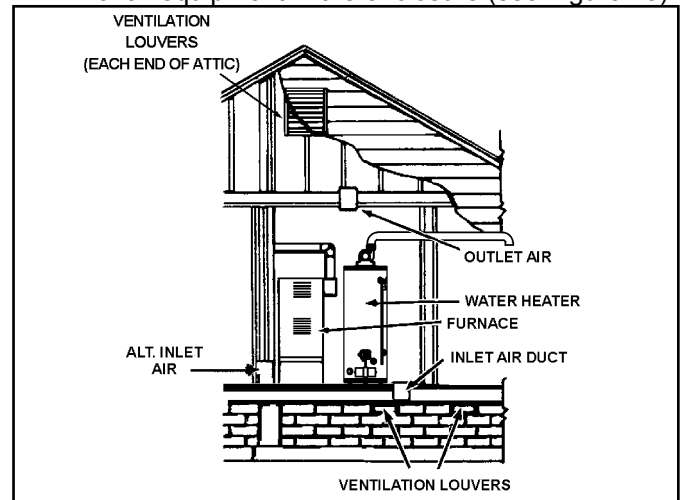
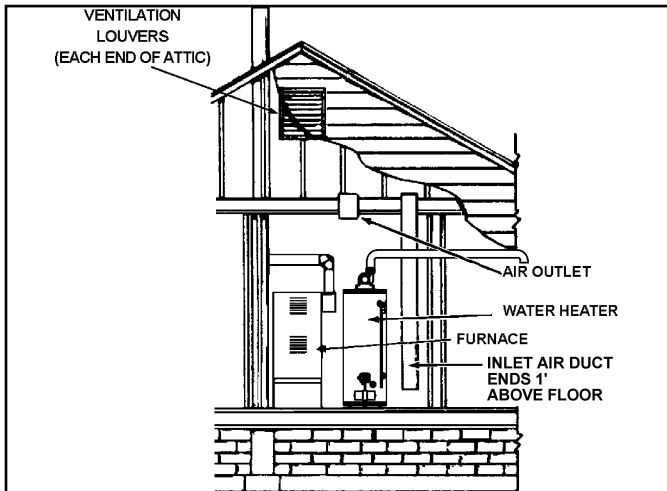

Figure 18

2. When communicating with the outdoors through vertical ducts, each opening shall have a minimum free area of 1 square inch per 4,000 Btu/hr of total input rating of all equipment in the enclosure (see Figure 19).

- When communicating with the outdoors through horizontal ducts, each opening shall have a minimum free area of 1 square inch per 2,000 Btu/hr of total input rating of all equipment in the enclosure (see Figure 20).



**Figure 19**

- When ducts are used, they shall be of the same cross-sectional area as the free area of the openings to which they connect. The minimum short side dimension of rectangular air ducts shall not be less than 76mm (3 in.) (see Figure 20).

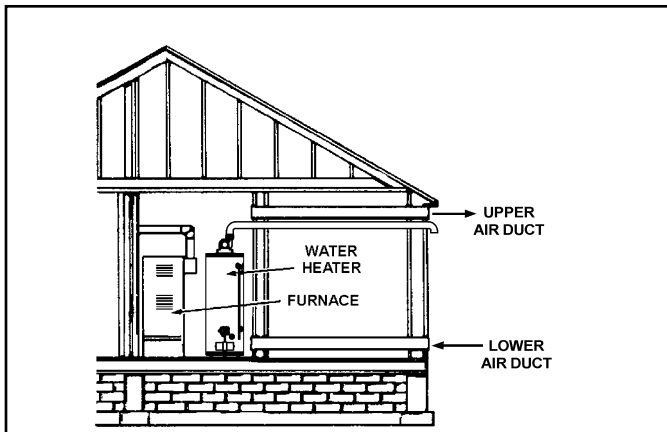

**Figure 20**

- Alternatively a single permanent opening may be used when communicating directly with the outdoors, or with spaces that freely communicate with the outdoors. The opening shall have a minimum free area of 1 square inch per 3,000 Btu/hr of total input rating of all equipment in enclosure (see Figure 21).

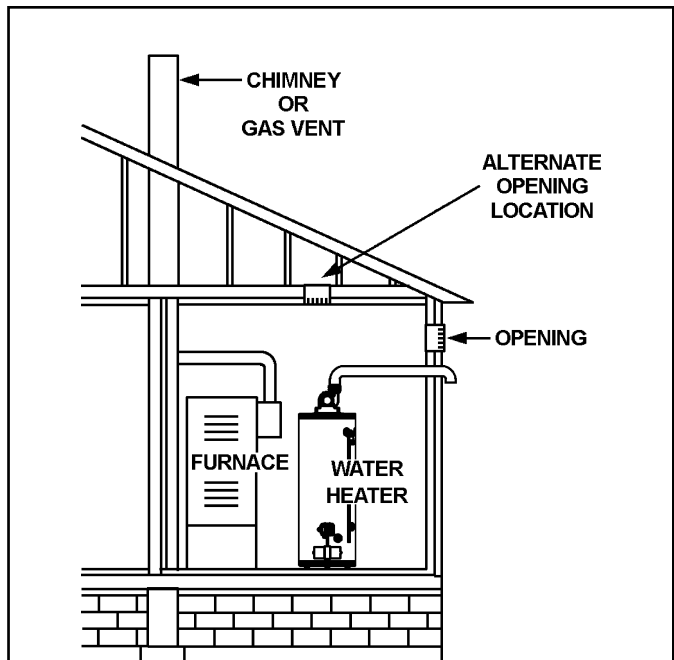

**Figure 21**

- Louvers and Grilles: In calculating free area, consideration shall be given to the blocking effect of louvers, grilles or screens protecting openings. Screens used shall not be smaller than 6mm (1/4 in.) mesh. If the free area through a design of louver or grille is known, it should be used in calculating the size opening required to provide the free area specified. If the design and free area is not known, it may be assumed that wood louvers will be 20-25 percent free area and metal louvers and grilles will have 60-75 percent free area. Louvers and grilles shall be fixed in the open position or interlocked with the equipment so that they are opened automatically during equipment operation.
- Special Conditions Created by Mechanical Exhausting or Fireplaces: operation of exhaust fans, ventilation systems, clothes dryers or fireplaces may create conditions requiring special attention to avoid unsatisfactory operation of installed gas utilization equipment.

### **CHEMICAL VAPOR CORROSION**

CORROSION OF THE FLUEWAYS AND VENT SYSTEM MAY OCCUR IF AIR FOR COMBUSTION CONTAINS CERTAIN CHEMICAL VAPORS. SUCH CORROSION MAY RESULT IN FAILURE AND RISK OF ASPHYXIATION. Spray can propellants, cleaning solvents, refrigerator and air conditioning refrigerants, swimming pool chemicals, calcium and sodium chloride (water softener salt), waxes, and process chemicals are typical compounds which are potentially corrosive. Do not store products of this sort near the heater. Also air which is brought in contact with the heater should not contain any of the chemicals. If necessary, uncontaminated air should be obtained from remote or outside sources. The Limited Warranty is voided when failure of water heater is due to a corrosive atmosphere. See Limited Warranty for complete terms and conditions.

# INSTALLING THE NEW WATER HEATER

## WATER PIPING

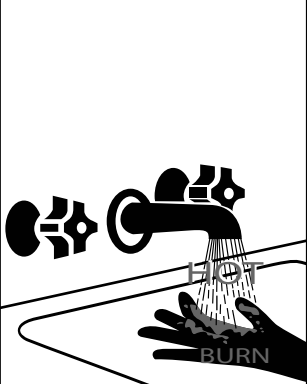
	<b>⚠ DANGER</b> Water temperature over 125°F can cause severe burns instantly resulting in severe injury or death.
	Children, the elderly and the disabled and are at highest risk of scald injury.  Feel water before bathing or showering.  Temperature limiting devices such as mixing valves must be installed when required by codes and to ensure safe temperatures at fixtures.

The water supply pressure should not exceed 80 psi. If this occurs, a pressure reducing valve with a bypass should be installed in the cold water inlet line. This should be placed on the supply to the entire house in order to maintain equal hot and cold water pressures.

### HOT WATER CAN SCALD:

Water heaters are intended to produce hot water. Water heated to a temperature which will satisfy space heating, clothes washing, dish washing, cleaning and other sanitizing needs can scald and permanently injure you upon contact. Some people are more likely to be permanently injured by hot water than others. These include the elderly, children, the infirm, or physically/mentally handicapped. If anyone using hot water fits into one of these groups or if there is a local code or state law requiring certain temperature water at the hot-water tap, then you must take special precautions. In addition to using lowest possible temperature setting that satisfies your hot water needs, a means such as a mixing valve, should be used at hot-water taps used by these people or at the water heater (see Figure 8 & Figure 9). Valves for reducing point of use temperature by mixing cold and hot water are also available.

### SPACE HEATING AND POTABLE WATER SYSTEMS

This appliance has been design certified as complying with American National Standard/CSA Standard for water heaters and are considered suitable for Water (Potable) Heating and Space Heating. **Note:** Water heaters used in combination water/space heating shall not be used in space heating only applications.

<b>⚠ WARNING</b>
<b>Toxic Chemical Hazard</b>
• Do not connect to non-potable water system.

Consult a Qualified Installer or Service Agency. Follow manufacturer's instructions for installation of valves. Before changing the factory setting on thermostat, read "Operating The Temperature Control System" section in this manual.

- This water heater should not be connected to any heating systems or components previously used with a non-potable water heating appliance.
- All piping components connected to this unit for space heating applications should be suitable for use with potable water.
- Toxic chemicals, such as those used for boiler treatment shall not be introduced into the potable water used for space heating.
- When the system requires water for space heating at temperatures higher than required for domestic water purposes, a mixing valve must be installed. Please refer to Figure 8 & Figure 9 for suggested piping arrangement.

**Note:** Water piping and vent piping occupy the space above the water heater. Plan the water piping to ensure it does not cause interference with the vent piping (see "Planning The Vent System").

If this water heater is to be used to supply both space heating and potable water, the instructions listed below must be followed:

- Be sure to follow the manual(s) shipped with the air handler or other type heating system.
- This water heater is not to be used as a replacement for an existing boiler installation.
- Do not use with piping that has been treated with chromates, boiler seal or other chemicals and do not add any chemicals to the water heater piping.
- If the space heating system requires water temperatures in excess of 120°F, a mixing valve must be installed, per the manufacturer's instructions, in the potable hot-water supply to limit the risk of scald injury.
- Pumps, valves, piping and fittings must be compatible with potable water.
- A properly installed flow control valve is required to prevent thermosiphoning. Thermosiphoning is the result of a continuous flow of water through the air handler circuit during the off cycle. Weeping (blow off) of the temperature-pressure relief valve (T&P) or higher than normal water temperatures are the first signs of thermosiphoning.
- The hot-water line from the water heater should be vertical past any mixing valve or supply line to the heating system to remove air bubbles from the system.
- Do not connect the water heater to any system or components previously used with non-potable water heating appliances when used to supply potable water.

## COMBO HEATING

This section serves as a guide for the installation and use of “Combo” heating systems utilizing a domestic water heater that has been specifically approved for such use. It is written for those knowledgeable in the required trades and professionals involved in the design and installation of Combo Heating Systems.

It is the responsibility of the installer/designer to follow all applicable codes to ensure the effectiveness and safety of the installation.

### System Requirements

The following requirements must be met for the installation of Combo Heating Systems:

1. All components used for the distribution of water in the heating loop must be suitable for potable water. These include all piping, fittings, solder and fluxes, pumps for circulation of water, valves, etc.
2. The water heater must not be connected to a hydronic heating system that has been used previously.
3. No boiler treatment chemicals of any kind shall be introduced into the system.
4. The Combo System components must be selected and sized to meet and maintain the total calculated demands for both domestic service hot water and space heating requirement. The sizing and installation must be performed in accordance with good engineering practice such as “ASHRAE Handbooks”, HRAI’s Unified Combo Guidelines, “Hydronics Institute Manuals”, ANSI Z223.1, CSA F280, National/Provincial Building Codes, ANSI and/or codes having jurisdiction.
5. The air handler (fan coil) and/or the circulating pump in a baseboard hydronic loop will require a dedicated 120V circuit. This must be provided and identified for this purpose.
6. All piping between the water heater and the air handler or hydronic baseboard loop must be adequately insulated to reduce heat loss.
7. If the local jurisdiction requires a back-flow preventer in the cold water line, an expansion tank of adequate size must be installed.
8. “Combo” Heating Systems require higher water temperatures than other applications. When the system is used to supply water for Combo Heating applications, a means, such as mixing valve, must be installed to temper the water in order to reduce scald hazard potential (see Figure 22 & Figure 23).

### Installation

The heating mode may be one of the following options:

- A. A fan coil/air handler (Figure 22).
- B. A hydronic baseboard (finned tube) loop/In floor heating (Figure 23).

The following is a list of requirements for the installation of option A or B.

1. Install shut-off valves and unions so that the water heater can be isolated from the heating module should servicing of the water heater become necessary.

2. Install a drain valve at the lowest point of the heating loop so that water can be drained from the heating module without affecting the water heater.
3. If the air handler does not have a venting means at the highest point of the piping arrangement, install an air bleed at the highest point of the plumbing arrangement.

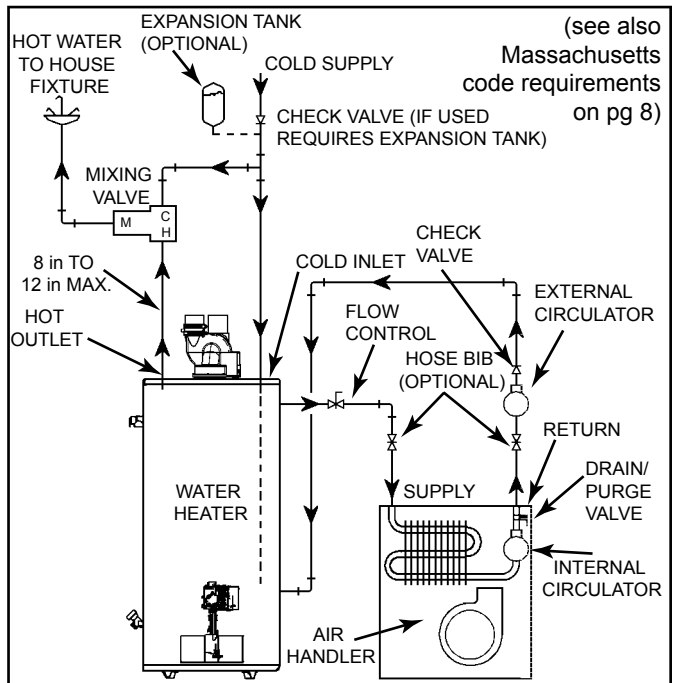

Figure 22

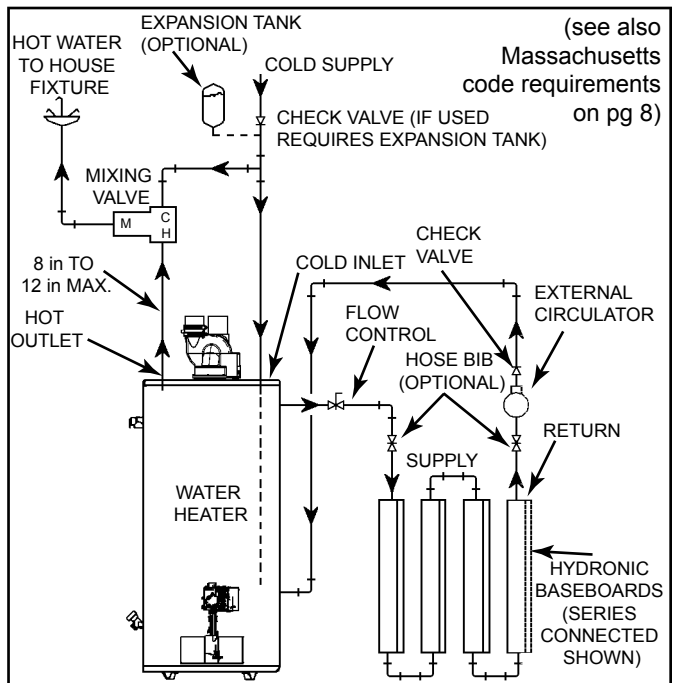

Figure 23

## CLOSED WATER SYSTEMS

Water supply systems may, because of code requirements or such conditions as high line pressure, among others, have installed devices such as pressure-reducing valves, check valves, and back flow preventers. Devices such as these cause the water system to be a closed system.

## THERMAL EXPANSION

As water is heated, it expands (thermal expansion). In a closed system, the volume of water will increase. As the volume of water increases, there will be a corresponding increase in water pressure due to thermal expansion. Thermal expansion can cause premature tank failure (leakage). This type of failure is not covered under the limited warranty. Thermal expansion can also cause intermittent temperature-pressure relief valve operation: water discharged from the valve due to excessive pressure build up. The temperature-pressure relief valve is not intended for the constant relief of thermal expansion. This condition is not covered under the limited warranty.

A properly-sized thermal expansion tank should be installed on all closed systems to control the harmful effects of thermal expansion. Contact a plumbing service agency or your retail supplier regarding the installation of a thermal expansion tank.

**Note:** To protect against untimely corrosion of hot and cold water fittings, it is recommended that di-electric unions or couplings be installed on this water heater when connected to copper pipe.

## CAUTION

### Property Damage Hazard

- Avoid water heater damage.
- Install thermal expansion tank if necessary.
- Do not apply heat to cold water inlet.
- Contact qualified installer or service agency.

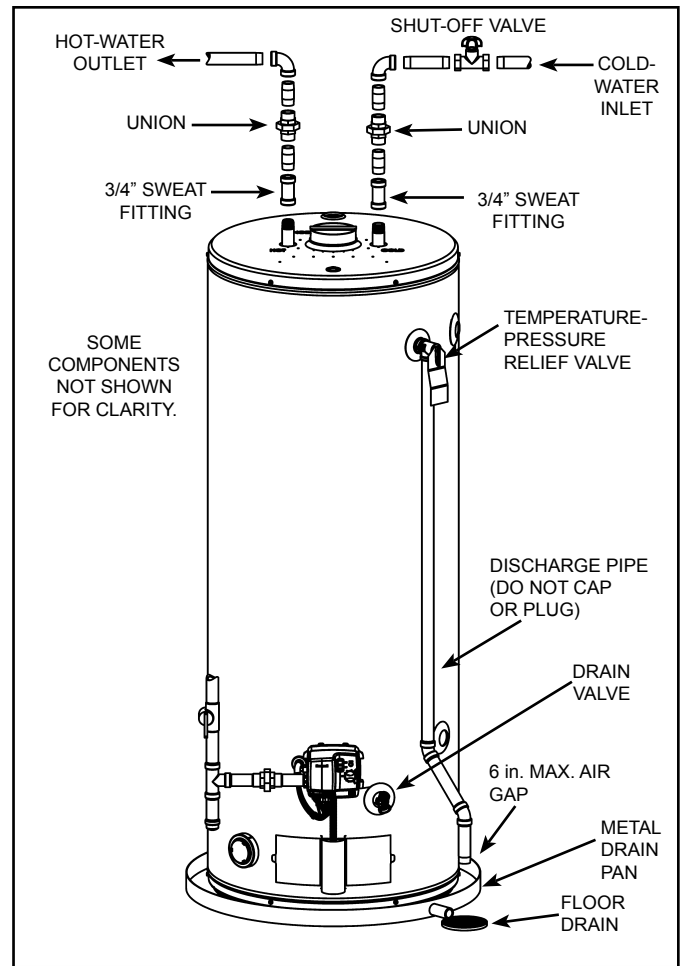
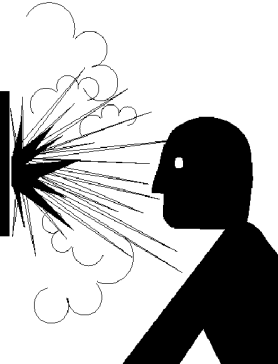

**Figure 24**

Figure 24 shows typical attachment of water piping to the water heater. The water heater is equipped with 3/4" NPT water connections.

**Note:** If using copper tubing, solder tubing to an adapter before attaching the adapter to the water heater connections. Do not solder the water lines directly to the water heater connections - it will harm the dip tube and heat traps and damage the tank.

## TEMPERATURE-PRESSURE RELIEF VALVE

 <b>WARNING</b>	
	<b>Explosion Hazard</b>
	<ul style="list-style-type: none"><li>• Temperature-pressure relief valve must comply with ANSI Z21.22-CSA4.4 and ASME code.</li><li>• Properly sized temperature-pressure relief valve must be installed in opening provided.</li><li>• Do not plug, block, or cap the discharge line.</li><li>• Failure to follow this warning can result in excessive tank pressure, serious injury or death.</li></ul>

This water heater is provided with a properly rated/sized and certified combination Temperature-Pressure Relief Valve (T&P valve) by the manufacturer. The valve is certified by a nationally recognized testing laboratory that maintains periodic inspection of production of listed equipment of materials as meeting the requirements for **Relief Valves for Hot Water Supply Systems, ANSI Z21.22-CSA 4.4**, and the code requirements of ASME.

If replaced, the new T&P valve must meet the requirements of local codes, but not less than a combination temperature-pressure relief valve rated/sized and certified as indicated in the above paragraph. The new valve must be marked with a maximum set pressure not to exceed the marked hydrostatic working pressure of the water heater (150 psi) and a discharge capacity not less than the water heater Btu/hr input rate as shown on the water heater's model rating plate.

For safe operation of the water heater, the temperature-pressure relief valve must not be removed from its designated opening nor plugged. The T&P valve must be installed directly into the fitting of the water heater designed for the relief valve. Install discharge piping so that any discharge will exit the pipe within 6 in. above an adequate floor drain, or external to the building. In cold climates it is recommended that it be terminated at an adequate drain inside the building. Be certain that no contact is made with any live electrical part.

The discharge opening must not be blocked or reduced in size under any circumstances. Excessive length (over 30 ft.), or use of more than four elbows can cause restriction and reduce the discharge capacity of the valve.

No valve or other obstruction is to be placed between the T&P valve and the tank. Do not connect discharge piping directly to the drain unless a maximum of 6 in. air gap is provided. To prevent bodily injury, hazard to life, or property damage, the relief valve must be allowed to discharge water in adequate quantities should circumstances demand. If the discharge pipe is not connected to a drain or other suitable means, the water flow may cause property damage.

<b>CAUTION</b>	
<b>Water Damage Hazard</b>	
<ul style="list-style-type: none"><li>• Temperature-pressure relief valve discharge pipe must terminate at an adequate drain.</li></ul>	

### T&P valve discharge pipe requirements:

- Shall not be smaller in size than the outlet pipe size of the valve, or have any reducing couplings or other restrictions.
- Shall not be plugged or blocked.
- Shall not be exposed to freezing temperatures.
- Shall be of material listed for hot water distribution.
- Shall be installed so as to allow complete drainage of both the temperature-pressure relief valve and the discharge pipe.
- Must terminate a maximum of 6 in. above an adequate floor drain or external to the building. In cold climates, it is recommended that the discharge pipe be terminated at an adequate drain inside the building
- Shall not have any valve or other obstruction between the relief valve and the drain.

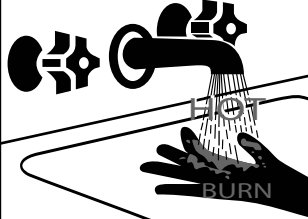
 <b>DANGER</b>	
	<ul style="list-style-type: none"><li>• Burn hazard.</li><li>• Hot water discharge.</li><li>• Keep clear of temperature-pressure relief valve discharge.</li></ul>

The T&P valve must be manually operated at least once a year. Caution should be taken to ensure (1) no one is in front of or around the outlet of the discharge line, and (2) the water manually discharged will not cause any bodily injury or property damage because the water may be extremely hot. If after manually operating the valve, it fails to completely reset and continues to release water, immediately close the cold-water inlet to the water heater, follow the draining instructions in this manual, and replace the temperature-pressure relief valve with a properly rated/sized new one.

**Note:** The purpose of a temperature-pressure relief valve is to prevent excessive temperatures and pressures in the storage tank. The T&P valve is not intended for the constant relief of thermal expansion. A properly sized thermal expansion tank must be installed on all closed systems to control thermal expansion, see “Closed Water Systems” and “Thermal Expansion” section.

### Temperature-Pressure Relief Valve and Pipe Insulation

The T&P valve installed on this water heater is covered by insulation to minimize heat loss. The insulation has a hole on the bottom side to accommodate the valve outlet and allow for the piping connection. Do not restrict the outlet opening of the T&P valve.

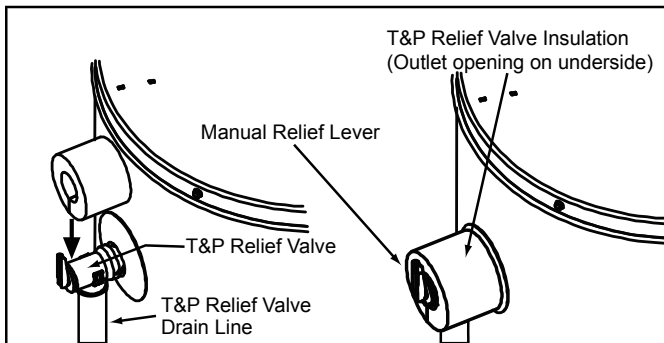

Figure 25

Locate the temperature and pressure relief valve on the water heater (also known as a T&P relief valve). See Figure 25.

1. Locate the slit running the length of the T&P relief valve insulation.
2. Spread the slit open and fit the insulation over the T&P relief valve. See Figure 25. Apply gentle pressure to the insulation to ensure that it is fully seated on the T&P Relief Valve. Once seated, secure the insulation with duct tape, electrical tape, or equivalent. **Important:** The insulation and tape must not block the discharge opening or hinder access to the manual relief lever (Figure 25). Ensure a discharge pipe is installed into the T&P valve discharge opening per the instructions in this manual.
3. Locate the hot water (outlet) & cold water (inlet) pipes to the water heater.
4. Locate the slit running the length of a section of pipe insulation.
5. Spread the slit open and slip the insulation over the cold water (inlet) pipe. Apply gentle pressure along the length of the insulation to ensure that it is fully seated around the pipe. Also, ensure that the base of the insulation is flush with the water heater. Once seated, secure the insulation with duct tape, electrical tape, or equivalent.
6. Repeat steps 5 and 6 for the hot water (outlet) pipe.
7. Add additional sections of pipe insulation as needed.

## HIGH ALTITUDE INSTALLATION

<b>⚠ WARNING</b>	
<b>Breathing Hazard - Carbon Monoxide Gas</b>	
	<ul style="list-style-type: none"> <li>• For operation above 10,100 ft. a high altitude orifice must be installed.</li> <li>• Contact a qualified installer or service agency.</li> </ul>
<p><b>Breathing carbon monoxide can cause brain damage or death. Always read and understand instruction manual.</b></p>	

This heater is approved for operation up to 10,100 ft. without alteration.

Failure to replace standard orifice with a high altitude orifice when installed above 10,100 ft. could result in improper and inefficient operation of the appliance, producing carbon monoxide gas in excess of safe limits, which could result in serious injury or death. Contact your gas supplier for any specific changes which may be required in your area.

## GAS PIPING

<b>⚠ WARNING</b>	
	<p style="text-align: center;"><b>Fire and Explosion Hazard</b></p> <ul style="list-style-type: none"> <li>• Do not use water heater with any gas other than the gas shown on the rating plate.</li> <li>• Excessive pressure to gas control valve can cause serious injury or death.</li> <li>• Turn off gas lines during installation.</li> <li>• Contact qualified installer or service agency.</li> </ul>

<b>⚠ WARNING</b>	
<p><b>Explosion Hazard</b></p> <p><b>Have a qualified technician make sure that the L.P. gas operating pressure does not exceed 14" water column.</b></p> <p><b>Failure to do so can result in death, explosion, or fire.</b></p>	



Make sure the gas supplied is the same type listed on the model rating plate. The inlet gas pressure must not exceed 14 inch w.c. for natural gas and propane gas. The minimum inlet gas pressure shown on the rating plate is that which will permit firing at rated input.

All gas piping must comply with local codes and ordinances or with the current edition of the “**National Fuel Gas Code**”, **ANSI Z223.1/NFPA 54**. Copper or brass tubing and fittings (except tin lined copper tubing) should not be used.

If the gas control valve/thermostat is subjected to pressures exceeding 1/2 psi, the damage to the gas control valve/thermostat could result in a fire or explosion from leaking gas.

If the main gas line shut-off serving all gas appliances is used, also turn “OFF” the gas at each appliance. Leave all gas appliances shut “OFF” until the water heater installation is complete.

A gas line of sufficient size must be run to the water heater. Consult the current edition of the “**National Fuel Gas Code**”, **ANSI Z223.1/NFPA 54** and your gas supplier concerning pipe size.

There must be:

- A readily accessible manual shut-off valve in the gas supply line serving the water heater, and
- A sediment trap (dirt leg) ahead of gas control valve/thermostat to help prevent dirt and foreign materials from entering the gas control valve/thermostat.
- A flexible gas connector or ground joint union between the shut-off valve and gas control valve/thermostat to permit servicing of the unit.

Be sure to check all the gas piping for leaks before lighting the water heater. Use a soapy water solution, not a match or open flame. Repair and retest as required. When finished, rinse off soapy solution and wipe dry.

<b>⚠ WARNING</b>	
	<b>Fire and Explosion Hazard</b>
	<ul style="list-style-type: none"> <li>• Use joint compound or tape compatible with propane.</li> <li>• Leak test before operating heater.</li> <li>• Disconnect gas piping and shut-off valve before pressure testing system.</li> </ul>

Use pipe joint compound or Teflon tape marked as being resistant to the action of gases.

The appliance and its gas connection must be leak tested before placing the appliance in operation.

The appliance and its individual shut-off valve should be disconnected from the gas supply piping system during any pressure testing of that system at test pressures in

excess of 1/2 psi. It should be isolated from the gas supply piping system by closing its individual manual shut-off valve during any pressure testing of the gas supply piping system at test pressures equal to or less than 1/2 psi.

Connecting gas piping to the gas control valve/thermostat of water heater can be accomplished by either of two methods shown in Figure 26 & Figure 27.

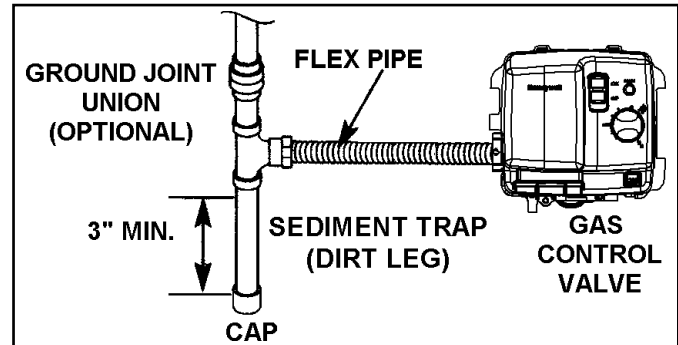

**Figure 26**

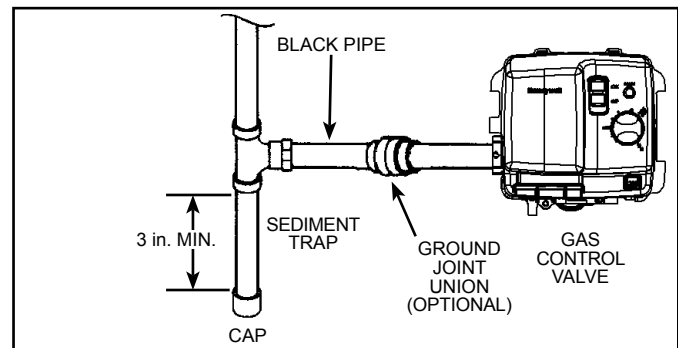

**Figure 27**

**SEDIMENT TRAPS/DIRT LEG**

<b>⚠ WARNING</b>	
	<b>Fire and Explosion Hazard</b>
	<ul style="list-style-type: none"> <li>• Contaminants in gas lines can cause fire or explosion.</li> <li>• Clean all gas piping before installation.</li> <li>• Install sediment trap in accordance with NFPA 54.</li> </ul>

Contaminants in the gas lines may cause improper operation of the gas control valve/thermostat that may result in fire or explosion. Before attaching the gas line be sure that all gas pipe is clean on the inside. To trap any dirt or foreign material in the gas supply line, a sediment trap (sometimes called a dirt leg) must be incorporated in the piping. The sediment trap should be either a tee fitting with a capped nipple in the bottom outlet or other device recognized as an effective sediment trap. If a tee fitting is used, it should be installed in conformance with one of the methods of installation shown in Figure 26 & Figure 27. Refer to the current edition of the “**National Fuel Gas Code**”, **ANSI Z223.1/NFPA 54**.

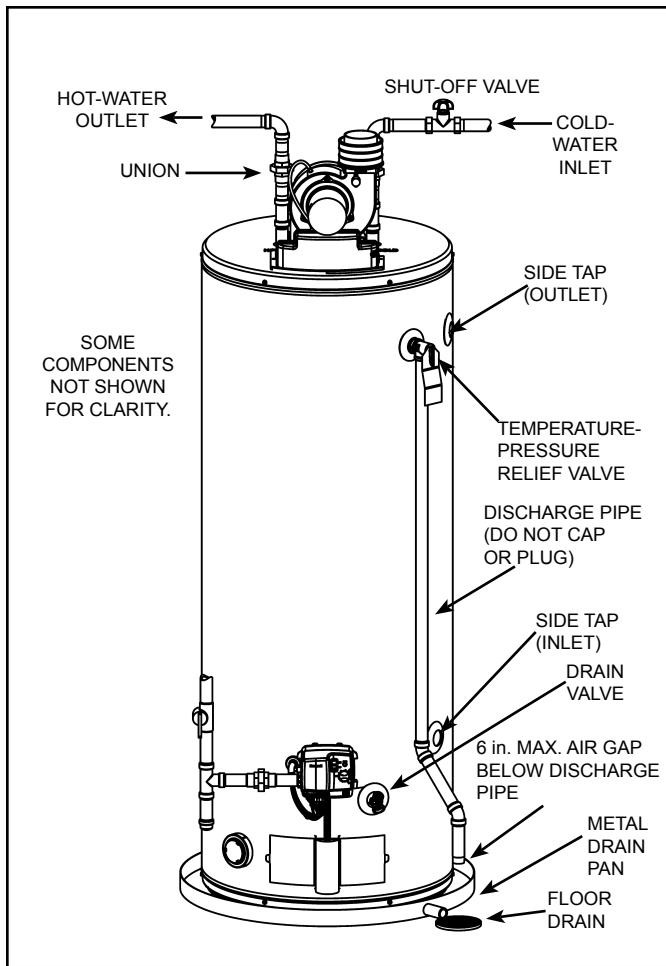

Figure 28

## FILLING THE WATER HEATER

### CAUTION

#### Property Damage Hazard

- Avoid water heater damage.
- Fill tank with water before operating.

- Do not insert the power cord into the electrical receptacle until the heater has been fully installed.
- Never use this water heater unless it is completely full of water. To prevent damage to the tank, the tank must be filled with water. Water must flow from the hot-water faucet before turning "ON" gas to the water heater.

To fill the water heater with water:

1. Close the water heater drain valve by turning handle to the right (clockwise). The drain valve is on the lower front of water heater (see Figure 28).
2. If the heater is equipped with plumbing side taps and they are not connected to piping, ensure that the side taps have been closed with pipe plugs.
3. Open all hot-water faucets served by the water heater to allow air to escape from the tank and the water piping. Ensure any shut-off valves between the heater and the faucets are the open position.

4. Open the cold-water supply valve to the water heater.
 

Notes:

  - The cold-water supply valve must be left open when the water heater is in use.
  - Avoid water leakage when filling the tank. Do not allow the insulation of the water heater to get wet as water can reduce the effectiveness of the insulation.
5. To ensure complete filling of the tank, allow air to exit. Check that the nearest hot-water faucet is still open. Allow water to run until a constant flow is obtained. This will let air out of the water heater and the piping.
6. Check all water piping and connections for leaks. Repair as needed.

## VENTING

All venting must comply with the current edition of the "National Fuel Gas Code", ANSI Z223.1/NFPA 54. This heater is certified to be installed using Schedule 40 PVC, ABS or CPVC or polypropylene plastic vent material. Only use approved material. All venting material and components must be joined with the approved primer/cleaner and solvent cement or mechanical seals (see "Polypropylene Vent Systems").

Use only Schedule 40 CPVC piping and fittings for the first linear 5 ft. of the outlet vent system. A 5 ft. section of 3" Schedule 40 CPVC vent pipe is supplied with the water heater for this purpose. If 4" venting is to be used it must be field supplied. For the rest of the outlet vent system use piping and fittings as defined above.

## WARNING

### Breathing Hazard - Carbon Monoxide Gas

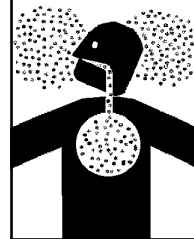

- Install vent system in accordance with codes.
- Do not operate water heater if flood damaged.
- Install water heater in accordance with the instruction manual.
- Do not operate if soot buildup is present.
- Do not obstruct water heater air intake(s) with insulating blanket.
- Do not place chemical vapor emitting products near water heater.
- Gas and carbon monoxide detectors are available.
- Never operate the heater unless it is vented to the outdoors and has adequate air supply to avoid risks of improper operation, fire, explosion or asphyxiation.
- Analyze the entire vent system to make sure that condensate will not become trapped in a section of vent pipe and therefore reduce the open cross sectional area of the vent.

Breathing carbon monoxide can cause brain damage or death. Always read and understand instruction manual.

**Important:** DO NOT common vent this water heater with any power vented appliance. DO NOT vent into a common chimney.

**TERMINATION CLEARANCES SIDEWALL POWER VENT**

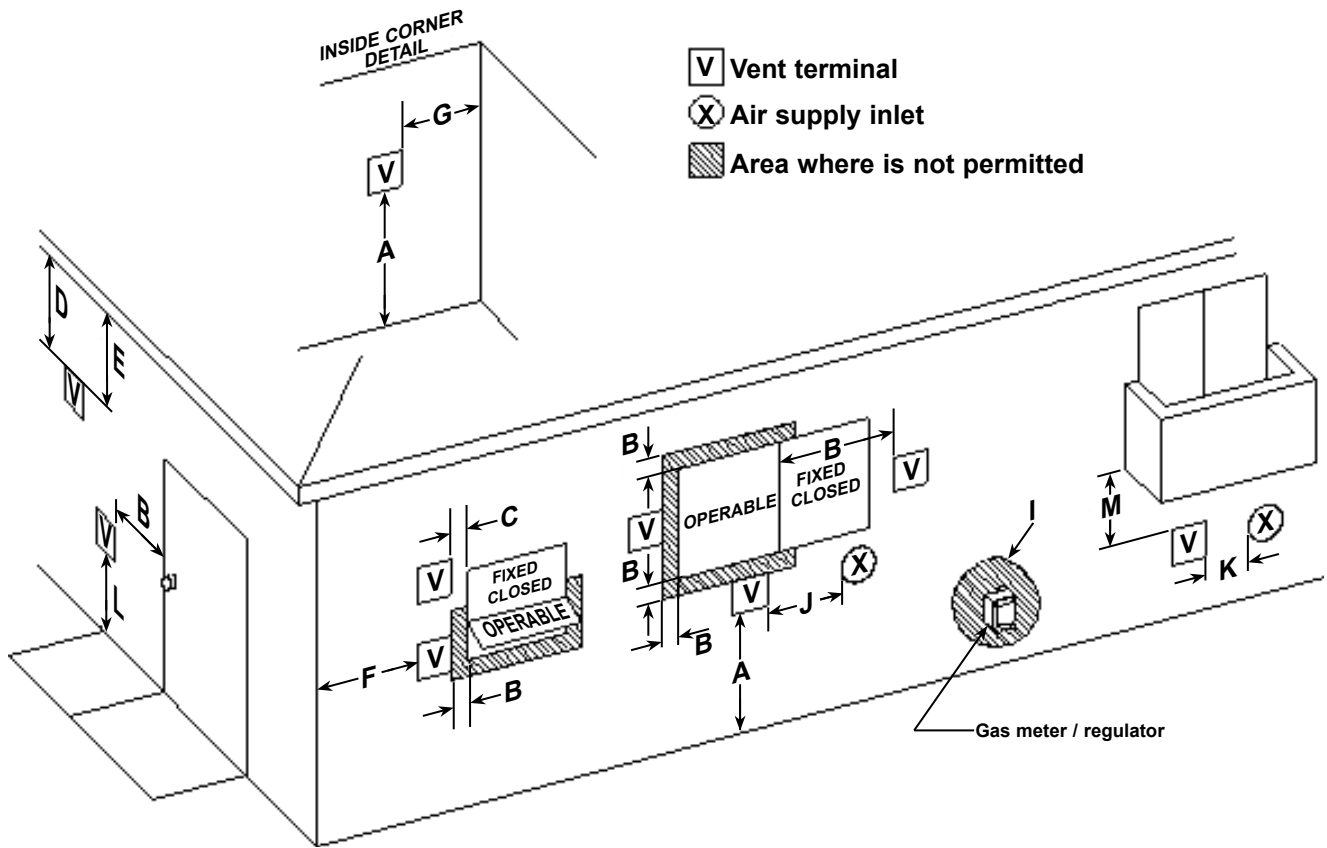

**Figure 29**

Vent terminal clearances for "Power Vent" installations. Power Vent configurations use room air for combustion.

A	Clearance above grade, veranda, porch, deck or balcony	12 in.	H	Clearance to each side of center line extended above meter/regulator assembly	N/A
B	Clearance to window or door that may be opened	4 ft. below or to side of opening; 1 ft. above opening	I	Clearance to service regulator vent outlet	3 ft.*
C	Clearance to permanently closed window	12 in.	J	Clearance to a non mechanical air supply inlet into building or combustion air inlet to any other appliance	4 ft. below or to side of opening; 1 foot above opening.
D	Vertical clearance to ventilated soffit located above the terminal within a horizontal distance of 2 ft. from the center line of the terminal	12 in.	K	Clearance to a mechanical air supply inlet	3 ft. above if within 10 ft. horizontally
E	Clearance to unventilated soffit	12 in.	L	Clearance above paved sidewalk or paved driveway located on public property	7 ft.
F	Clearance to outside corner	2 ft.	M	Clearance under veranda, porch, deck, or balcony	12 in.‡
G	Clearance to inside corner	18 in.			

In accordance with the current ANSI Z223.1/NFPA 54, National Fuel Gas Code.

‡ Permitted only if veranda, porch, deck, or balcony is fully open on a minimum of two sides beneath the floor.

## BLOWER ASSEMBLY INSTALLATION

1. This power vented water heater comes with blower assembly installed (see Figure 30).
2. After unit is set in place, make sure blower assembly is still mounted securely. Make sure there is no damage to blower.

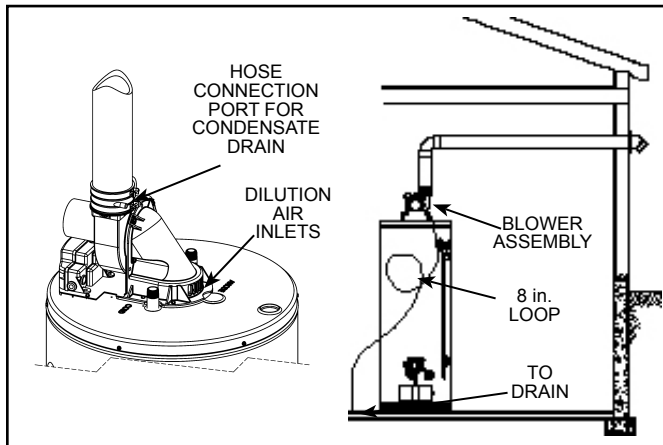

Figure 30

3. Make sure there is no packing material in the inlet or discharge of the blower.
4. Make sure that the plastic tubing is still attached from the air pressure switch to the port on the blower housing. Make sure the plastic tubing is not folded anywhere between the pressure switch and the blower housing (see Figure 38 thru Figure 40).
5. This water heater is a polarity sensitive appliance and will not operate if the power supply polarity is reversed. Power to this water heater must be wired properly (correct polarity).
6. Do not plug in power cord until vent system is completely installed. The Power Vent operates on 110-120 VAC. therefore a grounded outlet must be within reach of the 6 foot flexible power cord supplied with the heater. The power cord supplied may be used on a unit only where local codes permit. If local codes do not permit use of flexible power supply cord:
  - a. Make sure the unit is unplugged from the wall outlet. Remove the screw and open panel on the front of the junction box on the blower.
  - b. Cut the flexible power cord, leaving enough to be able to make connections. Remove the strain relief fitting from the box.
  - c. Install a suitable conduit fitting inside the enclosure.
  - d. Splice field wiring into existing wiring using code authorized method (wire nuts, etc).
  - e. Be certain that the neutral and line connections are not reversed when making these connections.

- f. Ground heater properly. This water heater must be grounded in accordance with the “**National Electrical Code**”, **NFPA 70** and/or local codes. These must be followed in all cases. The water heater must be connected to a grounded metal, permanent wiring system or an equipment grounding conductor must be run with the circuit conductors and connected to the equipment grounding terminal or lead on the water heater (see Figure 12; the wiring diagram).
  - g. Close the panel on the junction box. Make sure the access panel is properly secured.
7. The blower discharge boot is made to accept only straight sections of 2” or 3” pipe. To start off with an elbow, a short section of the straight pipe must be cut and glued into the end of the elbow that will mount on the discharge boot.
  8. A rubber coupling is an integral part of the vent system and must be used in every installation. Failure to do so may result in overheating, poor performance, nuisance lock-outs, personal injury or death.

## INSTALLATION OF VENT SYSTEM

Before beginning installation of piping system, thoroughly read the “Vent Pipe Preparation” section of this manual.

## PLANNING THE VENT SYSTEM

Plan the layout of the vent system from the vent termination to the water heater considering all of the 90 degree and 45 degree elbows plus the number of feet of pipe that would be needed to install the total vent system. The water heater must be vented to the outdoors as described in these instructions. This water heater must be vented separately from all other appliances.

The unit may be vented horizontally through a wall or vertically through the roof. Pipe runs must be adequately supported along both vertical and horizontal runs.

**Note:** Do not use an elbow as a support point. Elbows are not designed to carry the load or stresses of the venting system if they are rigidly held.

It is imperative that the first hanger (or support) be located on the horizontal run immediately adjacent to the first 90-degree elbow from the vertical rise. Support method used should isolate the vent pipe from the floor joists or other structural members to prevent the transmission of noise and vibration. Do not support, pin, or otherwise secure the venting system in a way that restricts the normal thermal expansion and contraction of the chosen venting material.

If the water heater is being installed as a replacement for an existing power vented heater in pre-existing venting, a thorough inspection of existing venting system must be performed prior to any installation work. Verify that correct material, as detailed in below, has been used, and that the minimum or maximum vent lengths and terminal location as detailed in this manual have been met.

## POLYPROPYLENE VENT SYSTEMS

Polypropylene vent systems do not use cement to connect the pipe and elbow sections but use a push together gasket seal method. Do not attempt to connect polypropylene with sealant cement.

Polypropylene vent systems are designed to use specific adaptors to connect into the rubber coupling on the top of the blower. These are available through your venting supplier.

The PVC vent termination elbow supplied with this heater has been certified to be used with polypropylene vent systems. A polypropylene to PVC end connection is required and is available through your supplier.

Optional wall plates that fit the polypropylene venting are also available through your supplier.

Carefully inspect the entire venting system for any signs of cracks or fractures, particularly at joints between elbows and other fittings and straight runs of vent pipe. Check system for signs of sagging or other stresses in joints as a result of misalignment of any components in the system. If any of these conditions are found, they must be corrected in accordance with the venting instructions in this manual before completing installation and putting the water heater into service.

The vent piping shall be connected to the blower with the rubber coupling and secured with gear clamps. The coupling and clamps are provided with the heater.

Even though the flue gas temperature leaving the blower is hot, some installations will have water condense in the vent piping. If this occurs, then adequate means of draining and disposing of the condensate shall be made by the installer.

## CONDENSATE

Condensate formation does not occur in all installations of power vented water heaters, but should be drained on installations where it can form in the venting system. Condensation in the venting system of power vented water heaters is dependent upon installation conditions including, but not limited to, ambient temperature and humidity of installation location, ambient temperature and humidity of venting space, vent discharge and slope, and product usage. In certain conditions, installations in unconditioned space or having long horizontal or vertical vent runs can accumulate condensate. Long lengths of venting that pass through cool/cold areas will experience condensation. The vent pipe should be sloped upwards away from the blower assembly, then adequate means for draining and disposing of the condensate needs to be made by the installer. If installation conditions cause condensation, install a condensate trap loop approximately 8 in. in diameter using 3/8 in. plastic hose. Connect the hose to the built-in drain port of the rubber coupling of the blower assembly (see Figure 30). Loop the hose in a vertical position as shown. The tube loop must be filled with water at least half way prior to operating the heater. Ensure the end of the tube has access to a drain as condensate will flow from the end. Secure the tubing to the side of the heater. Prior to operating the water heater, make sure

the removable cap is installed on the drain port (if a drain hose is not needed).

**Note:** This cap must remain in place if a drain hose is not installed.

## EXHAUST VENTING

This heater is designed to exhaust the products of combustion (flue gases) to the outdoors using a sealed piping system. Table 2 lists the allowable vent materials and sizing information. Figure 34 shows the general venting layout while Figure 35 thru Figure 37 show various end termination details and clearances. Connection of the venting piping to the blower is shown in Figure 38 thru Figure 40.

Correct installation of the venting system is essential to the safe and efficient operation of this water heater. Vent piping must be installed in accordance with all applicable codes. All installations shall meet the requirements as stated in the current edition of the “**National Fuel Gas Code, ANSI Z223.1/NFPA 54**”.

**Note:** The information provided in Figure 31 is intended as a guideline for good vent installation practices only and is not intended to restrict venting options beyond those restrictions established by the current edition of the “**National Fuel Gas Code, ANSI Z223.1/NFPA 54**” or any applicable local and state codes.

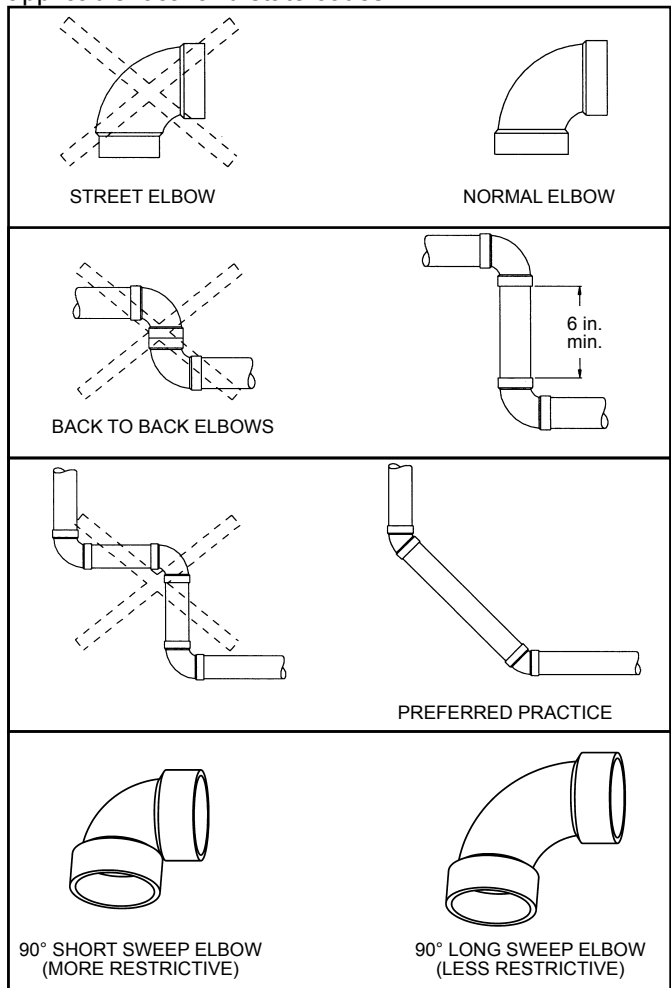

Figure 31

### Important Notes and Warnings

- This heater is certified to be installed using PVC, CPVC, ABS or polypropylene plastic vent material. Only use approved material. All venting material and components must be joined with the approved primer/cleaner and solvent cement or mechanical seals (see “Polypropylene Vent Systems”).
- Do not common vent this heater with any other appliance.
- During operation the plastic piping will expand as it heats up and contract as it cools down. This is normal for this type of venting. Rigidly fastening the vent piping can cause undue stress that may result in the cracking or fracturing the vent piping material. A fracture of the venting pipe may pose a serious safety hazard. To prevent stressing of the vent system, all hangers and supports must allow the vent piping freedom to move.
- Use long sweep elbows wherever possible. Closely-coupled elbows and short radius elbows can reduce the venting capacity.
- All power vented water heaters generate a certain amount of operational noise. In order to minimize noise transmission to the support structure, use isolation pads between the pipe hangers and the vent pipe.
- Most power vent installations develop some condensation in the vent piping. When using long runs of venting or when the venting passes through cold or unheated areas, considerable amounts of condensate from the flue gases can develop. Provision must be made for the condensate to drain freely from the system or to be collected in a condensate trap(s) that can be drained. Damage or fracture of the vent piping may occur if the condensate is allowed to collect and freeze. Pooling of condensate can restrict airflow and can cause nuisance failures of the system.

### Venting terminations and sizing

- Heaters are supplied with a 3”x3” rubber coupling to attach the venting to the blower and a 3”, 45° vent termination elbow.
- Supplied with this heater are several vent termination screens (see Figure 32).

Installed in the vent termination elbow, the vent screen is required to keep foreign objects, rodents and small birds from entering the venting system. These screens have been sized to ensure maximum energy efficiency of the vent system based on the “equivalent length” of the vent piping. **CHOOSE ONLY the ONE SCREEN THAT MATCHES YOUR VENTING CONFIGURATION** (see Figure 32). How to determine the “equivalent length” is shown in Figure 34 and in Table 2.

### Vent screen installation

- Install the appropriate vent screen into the vent termination elbow.
- Gently push the screen into the termination elbow until it sits against the inside shoulder.
- The metal wire screens are self-securing.
- Plastic screens must be secured with (2) screws:
  1. Install plastic screen into elbow (see Figure 33).

2. Orient screen as shown in see Figure 33 with an opening at the bottom of the assembly and the smooth side facing in.
3. Ensure screen is fully seated against shoulder in elbow.
4. Secure screen in place with screws (field supplied) (see Figure 33).

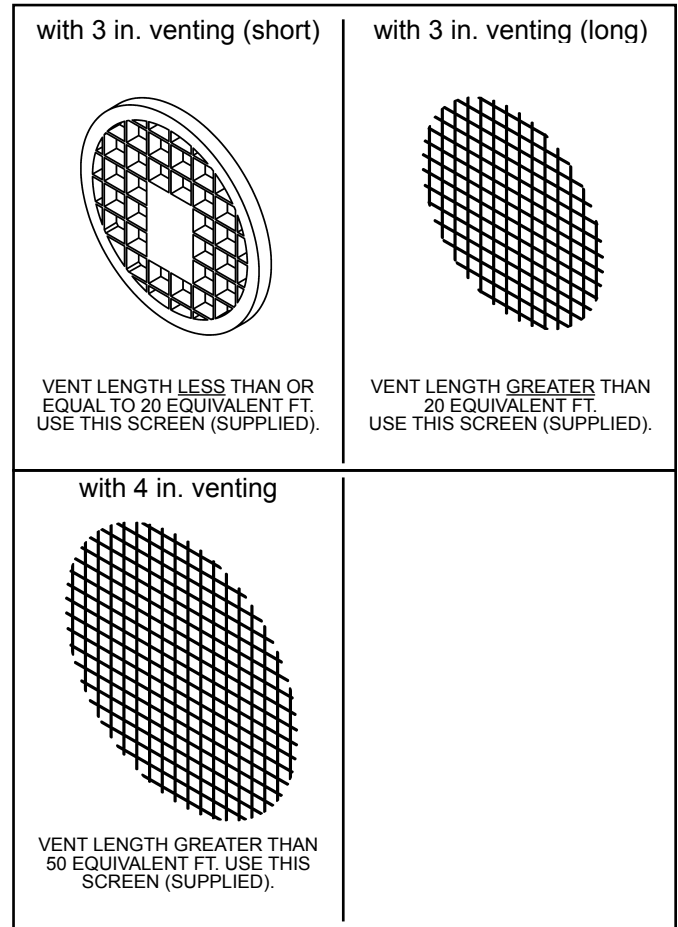

Figure 32

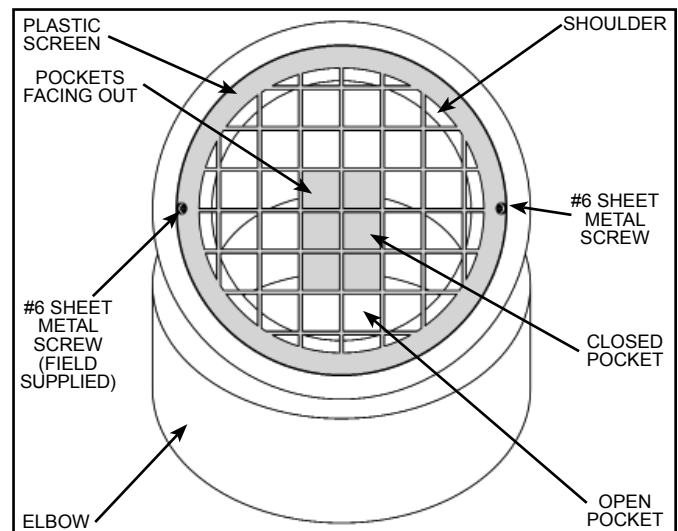

Figure 33

### Calculating Equivalent Feet

WATER HEATER MODEL	HEATER INPUT (Btu/hr)	VENT SIZE (Inside Diam.)	PRESSURE SWITCH SETTING	MAXIMUM EQUIVALENT VENT LENGTH	MINIMUM EQUIVALENT VENT LENGTH
75 gal.	76,000	3"	-0.90 in. w.c.	50' + termination elbow and screen*	7' + termination elbow and screen*
		4"		125' + termination elbow and screen*	50' + termination elbow and screen*

\* see Figure 32, "Venting terminations and sizing" and "Vent screen installation".

Equivalent lengths of straight pipe for various elbows using Schedule 40 PVC, CPVC, ABS and polypropylene.

Size	Type	Short Sweep/ Short Radius	Long Sweep/ Long Radius	Notes:
3" 4"	90° elbow	8'	5'	1. Use long radius elbows where possible. Minimum distance between 90° elbows should be 6 in. wherever possible. 2. Venting systems may use a maximum of five (5) 90° elbows. 3. Use proper screen termination (see Figure 32).
3" 4"	45° elbow	4'	2.5'	

**Table 2**

**Note:** Use only Schedule 40 CPVC piping and fittings for the first linear 5 ft. of the outlet vent system.

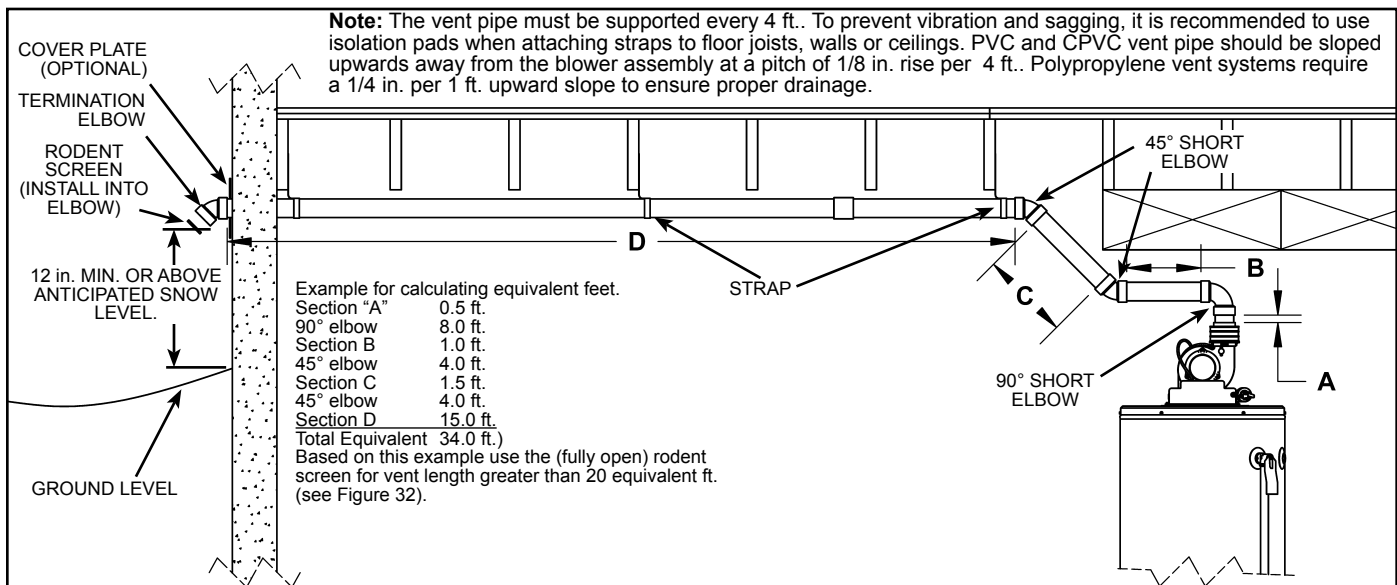

**Figure 34**

## Venting instructions

1. Plan the venting layout starting at the vent termination and work back toward the heater. Take into consideration the style and position of the vent termination, the vent pipe routing, elbows and connectors required and the necessary support hangers.
2. Venting should be as direct as possible with the fewest number of fittings. Use long radius 45 degree and long radius 90 degree elbows wherever possible.
3. Avoid using 90 degree elbows "back to back" and do not use street elbows. Maintain a minimum 6 in. straight section between elbows. Closely coupled and short radius elbows reduce the venting capacity. Figure 31 shows examples of vent pipe connections.
4. **DO NOT USE AN ELBOW AS A SUPPORT POINT.** Elbows are not designed to carry the weight of the venting system.
5. Calculate "Equivalent Vent Length" before starting. Do not exceed the values shown in Table 2. An example of how this length is determined is shown in Figure 34. The value from your calculations should also be used to determine which rodent screen to install into the vent termination elbow.
6. Measure the vent piping and cut to required lengths. Pipes must be cut at right angles and deburred to ensure a good smooth fit with sufficient overlap for the glue joints. Correct any interference conditions.
7. Provide support hangers for horizontal vent piping every 4 ft. to prevent sagging and stress. Provide a minimum of 1/8 in. rise per 4 ft. of vent piping to ensure adequate drainage (polypropylene vent systems require a 1/4 in. rise per 1 ft. of vent pipe). Horizontal vent piping must not sag to form valleys where condensate can collect. Vertical venting shall be supported every 5 ft.. Use appropriate support straps and vibration isolators (foam pads) on straight sections only. Allow sufficient clearance for expansion and contraction of the venting system.
8. At the point where the venting exits the building, cut a 3-1/2" hole for 3" venting or a 4-1/2" hole for 4" venting. For sidewall applications, use the appropriate metal cover plate as a template to mark the hole for the vent pipe to pass through the wall. **BEWARE OF CONCEALED WIRING AND PIPING INSIDE THE WALL.**
9. Insert the vent piping through this hole and secure into position. Connect the vent pipe to the end termination elbow as shown in Figure 35 thru Figure 37.
10. Dry fit all vent pipes, elbows, connectors and fittings before joining any parts with solvent cement. **PARTS MUST FIT WITHOUT STRESS OR BENDING OF ANY SECTION** and each connection must overlap a minimum of 1/2 in.. Do not force fit any of the connections. Use only the appropriate solvent cement. **Caution:** Solvent cements may produce flammable vapors. Use only in well-ventilated areas and keep away from all sources of ignition.

**Note:** DO NOT use solvent cement on polypropylene vent systems.

11. Install the properly sized rodent screen into the outlet elbow and secure with a small quantity of silicone sealant. Refer to Figure 32 to determine the proper screen.
12. Do not seal the vent piping to the wall until the venting is properly connected to the blower assembly.
13. Complete the venting installation by sealing around the termination assembly where it passes through the outside wall, inside and out, with silicone or other suitable sealant. Apply enough sealant to secure the (optional) cover plate to the wall.

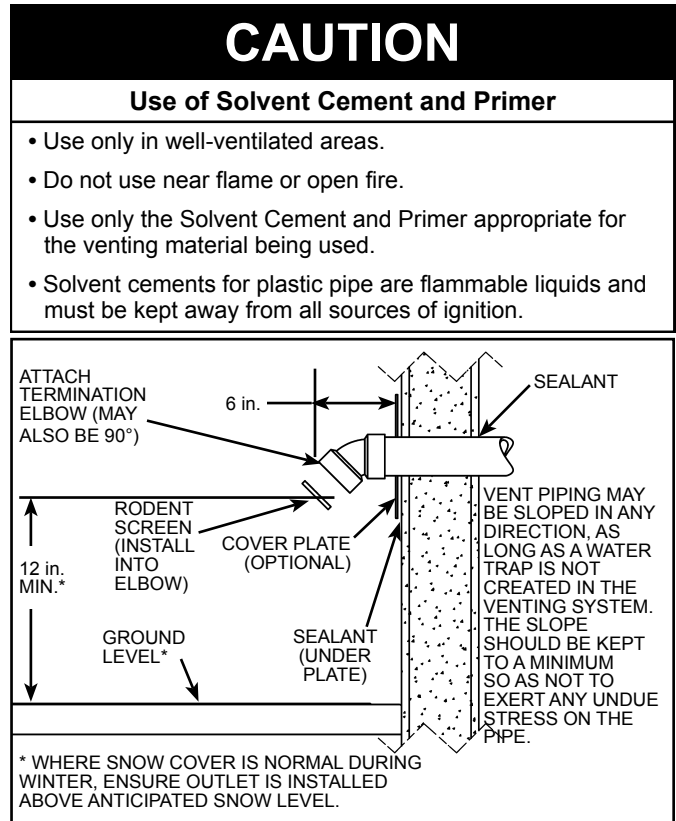

Figure 35

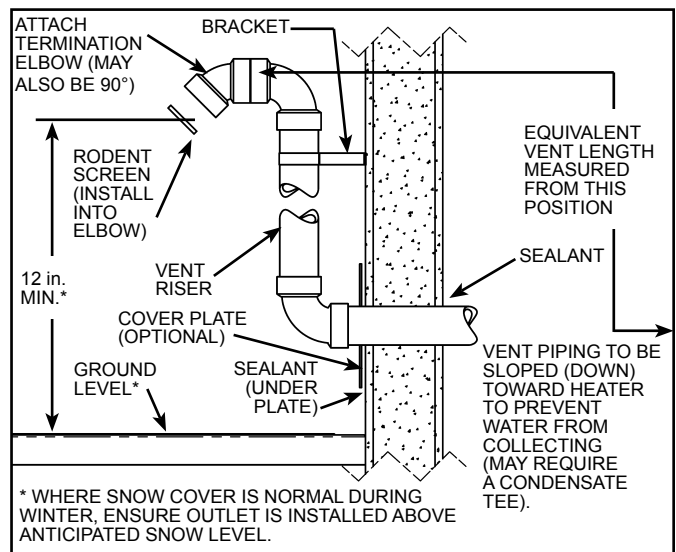

Figure 36



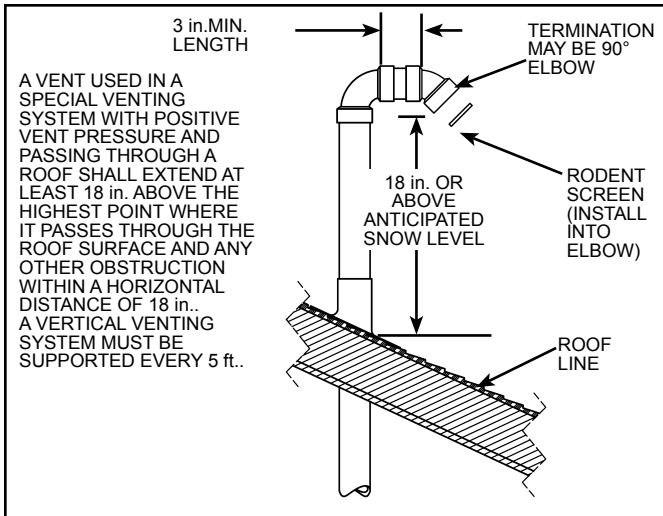

Figure 37

### Vent pipe connection to blower

1. The CPVC vent piping connects into the rubber coupling located on the top of the blower assembly. This coupling includes gear clamps to connect the venting to the blower. These connections must be properly seated and tightened to prevent the leakage of flue gases into the area. See Figure 38 thru Figure 40.
2. The water heaters are supplied with a 3" rubber coupling to accept the vent pipe. **Note:** Polypropylene vent systems require separate adaptor.
3. Before installing clean and lightly sand the end of the CPVC plastic vent piping that will connect into the rubber coupling. For polypropylene vent systems follow manufacturer's instructions.
4. Loosen the upper clamp on the rubber coupling and insert the sanded end of the vent piping a full 1-1/4 in.. Do not use glue or sealant in the rubber coupling. Check that there is no stress on the connection or the vent piping that may be caused by twisting or bending.
5. Tighten the upper clamp so that the vent piping is firmly secured in the coupling and is gas tight. Do not over tighten or cause distortion of any of the parts. Ensure the bottom of the rubber coupling is firmly seated on the blower outlet and that the lower gear clamp is also secure. Check to ensure there is no distortion or movement of the clamped assembly once it is completed.
6. If the outlet vent pipe is to be turned horizontally directly off the blower, a 3 in. long section of CPVC pipe may be cut from the 5 ft. (supplied) section of 3" Schedule 40 CPVC vent pipe. This is to be used to connect the CPVC outlet vent pipe elbow to the water heater (see Figure 40). This elbow SHALL be used in equivalent length calculations but does NOT contribute to the first 5 ft. of the outlet vent system (see "Venting").

<h1>CAUTION</h1>
<b>Property Damage Hazard</b>
<ul style="list-style-type: none"> <li>• Do not overtighten the top and bottom gear clamps of the rubber coupling.</li> <li>• Do not apply solvent cement or silicone to the rubber coupling connection.</li> </ul>

### Coupling installations according to vent sizes

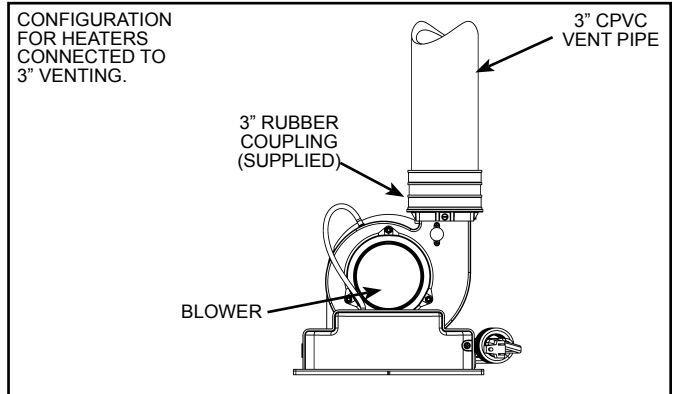

Figure 38

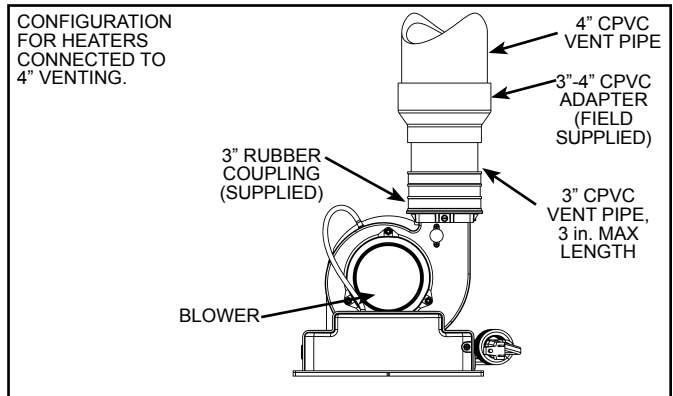

Figure 39

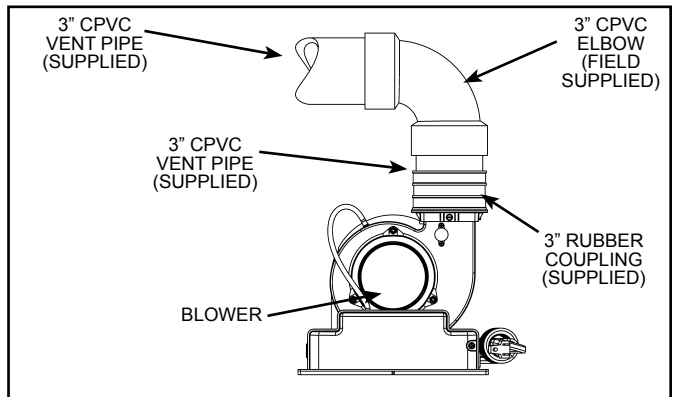

Figure 40

## BLOWER EXHAUST DIRECTION

The blower assembly may be rotated 90 degree clockwise or counterclockwise to allow horizontal venting in areas having restricted space above the water heater. To rotate the blower outlet, remove the four nuts (with 11/32" nut driver) (see Figure 41), securing the flue collector to the blower housing. Pull the blower assembly forward to free it from the mounting studs. Rotate the blower housing clockwise or counter-clockwise and align the four holes and screws together. Reattach the blower housing to the flue collector.

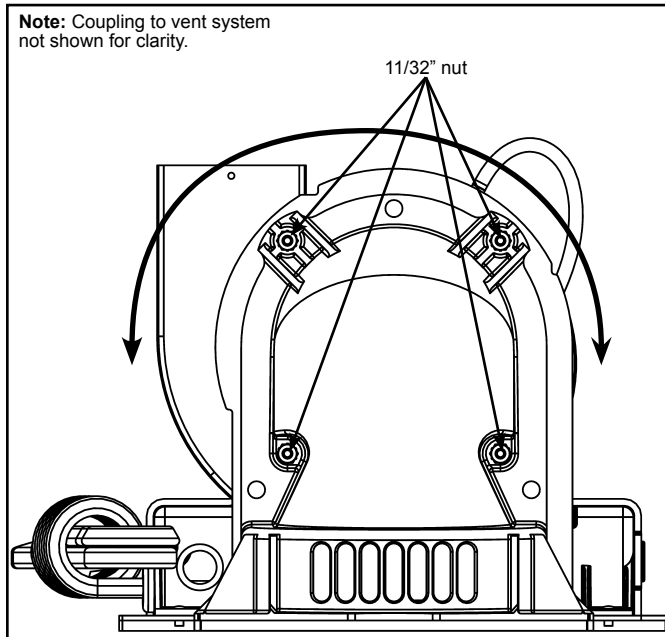

Figure 41

## VENT PIPE PREPARATION

### 1. INITIAL PREPARATION

- Make sure the solvent cement you are planning to use is designed for the specific application you are attempting.
- Know the physical and chemical characteristics and limitations of the PVC and CPVC piping materials that you are about to use.
- Know the reputation of your manufacturer and their products.
- Know your own qualifications or those of your contractor. The solvent welding technique of joining PVC and CPVC pipe is a specialized skill just as any other pipe fitting technique.
- Closely supervise the installation and inspect the finished job before start-up.
- Contact the manufacturer, supplier, or competent consulting agency if you have any questions about the application or installation of PVC and CPVC pipe.
- Take the time and effort to do a professional job. Shortcuts will only cause you problems and delays in start-up. By far, the majority of failures in PVC and CPVC systems are the result of shortcuts and/or improper joining techniques.

### 2. SELECTION OF MATERIALS (PCV and CPVC VENTING)

- Cutting Device - Saw or Pipe Cutter
- Deburring Tool, Knife, File, or Beveling Machine (2" and above)
- Brush - Pure Bristle
- Rag - Cotton (Not Synthetic)
- Primer and Cleaner
- Solvent Cement - PVC for PVC Components and CPVC for CPVC Components only
- Containers - Metal or Glass to hold Primer and Cement. Select the type of PVC or CPVC materials to be used on the basis of their application with respect to chemical resistance, pressure rating, temperature characteristics, etc.
- Insertion Tool - Helpful for larger diameter pipe and fittings 6" and above.

## ⚠ WARNING

### Fire or Explosion Hazard

- Do not store or use gasoline or other flammable vapours and liquids in the vicinity of this or any other appliance.
- Avoid all ignition sources if you smell gas.
- Do not expose water heater control to excessive gas pressure.
- Use only gas shown on rating plate.
- Maintain required clearances to combustibles.
- Keep ignition sources away from faucets after extended period of non-use.



Read instruction manual before installing, using or servicing water heater.



## ⚠ WARNING

### Fire or Explosion Hazard

- Do not store or use gasoline or other flammable vapors and liquids in the vicinity of this or any other appliance.
- Avoid all ignition sources if you smell gas.
- Do not expose water heater control to excessive gas pressure.
- Use only gas shown on rating plate.
- Maintain required clearances to combustibles.
- Keep ignition sources away from faucets after extended period of non-use.



Read instruction manual before installing, using or servicing water heater.



### Primer:

It is recommended that Tetrahydrofuran (THF) be used to prepare the surfaces of pipe and fittings for solvent welding. Do not use water, rags, gasoline or any other substitutes for cleaning PVC or CPVC surfaces. A chemical cleaner such as MEK may be used.

### Cement:

The cement should be a bodied cement of approximately 500 to 1600 centipoise viscosity containing 10-20% (by weight) virgin PVC material solvated with Tetrahydrofuran (THF). Small quantities of Dimethyl Formamide (DMF) may be included to act as a retarding agent to extend curing time. Select the proper cement; Schedule 40 cement should be used for Schedule 40 pipe. Never use all-purpose cements, commercial glues and adhesives or ABS cement to join PVC or CPVC pipe and fittings. To join PVC and CPVC materials, use ATSM F-493 compliant cement.

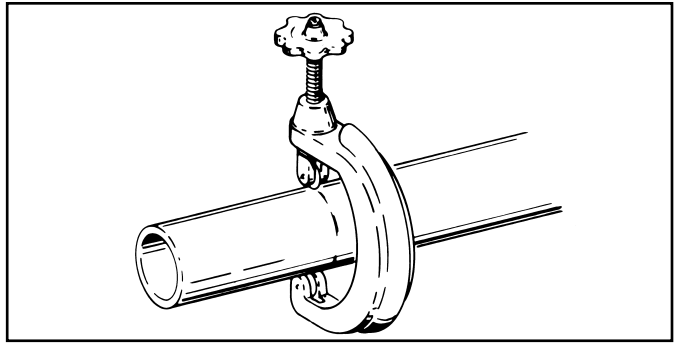

Figure 42

### B. Deburring

Use a knife, plastic pipe deburring tool, or file to remove burrs from the end of small diameter pipe. Be sure to remove all burrs from around the inside as well as the outside of the pipe. A slight chamfer (bevel) of about 10°-15° should be added to the end to permit easier insertion of the pipe into the end of the fitting. Failure to chamfer the edge of the pipe may remove cement from the fitting socket, causing the joint to leak.

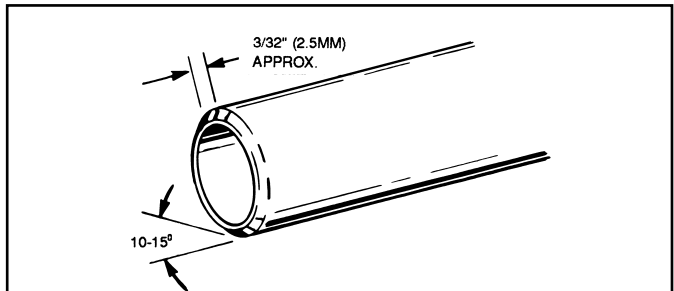

Figure 43

### C. Test dry fit of the joint

Tapered fitting sockets are designed so that an interfaced fit should occur when the pipe is inserted about 1/3 to 2/3 of the way into the socket. Occasionally, when pipe fitting dimensions are at the tolerance extremes, it will be possible to fully insert dry pipe to the bottom of the fitting socket. When this happens, a sufficient quantity of cement must be applied to the joint to fill the gap between the pipe and fitting. The gap must be filled to obtain a strong, leak-free joint.

	<b>WARNING</b>
	<b>Fire Hazard</b>
	<ul style="list-style-type: none"><li>• Primers and cements are extremely flammable, and must not be stored or used near heat or open flame.</li><li>• Also, use only in a well ventilated area.</li></ul>

### Applicators:

Select a suitable pure bristle type paint brush. Use a proper width brush or roller to apply the primer and cement (see chart below). Speedy application of cement is important due to its fast drying characteristics. IMPORTANT NOTE: A dauber type applicator should only be used on pipe sizes 2" and below. For larger diameter pipe, a brush or roller must be used.

RECOMMENDED BRUSH* SIZE FOR PRIMER AND CEMENT APPLICATIONS	
Nominal Pipe (IPS)	Brush Size
3	1.5" - 2.5"
*USE ONLY NATURAL BRISTLE	

Table 3

## 3. MAKING THE JOINT

### A. Cutting

Pipe must be squarely cut to allow for the proper interfacing of the pipe end and the fitting socket bottom. This can be accomplished with a miter box saw or wheel type cutter. Wheel type cutters are not generally recommended for larger diameters since they tend to flare the corner of the pipe end. If this type of cutter is used, the flare on the end must be completely removed.

**Note:** Power saws, if used, should be specifically designed to cut plastic pipe.

#### D. Inspection, cleaning, priming

Visually inspect the inside of the pipe and fitting sockets and remove all dirt, grease or moisture with a clean dry rag. If wiping fails to clean the surfaces, a chemical cleaner must be used. Check for possible damage such as splits or cracks and replace if necessary.

#### Depth-of-entry

Marking the depth of entry is a way to check if the pipe has reached the bottom of the fitting socket in Step F. Measure the fitting depth and mark this distance on the pipe O.D. You may want to add several inches to the distance and make a second mark as the primer and cement will most likely destroy your first one.

Apply primer to the surface of the pipe and fitting socket with a natural bristle brush. This process softens and prepares the PVC or CPVC for the solvent cementing step. Move quickly and without hesitation to the cementing procedure while the surfaces are still wet with primer.

#### E. Application of solvent cement

- Apply solvent cement evenly and quickly around outside of pipe at a width a little greater than the depth of the fitting socket.
- Apply a light coat of cement evenly around the inside of the fitting socket. Avoid puddling.
- Apply a second coat of cement to the pipe end.

	<b>WARNING</b>
	<b>Fire Hazard</b> <ul style="list-style-type: none"><li>• Cans of cement and primer should be closed at all times when not in use to prevent evaporation of chemicals and hardening of cement.</li><li>• They are also very flammable and should be kept away from heat or flame.</li></ul>

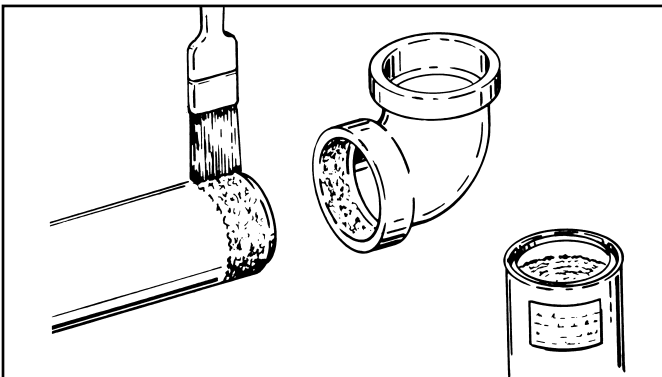

Figure 44

#### F. Joint assembly

Working quickly, insert the pipe into the fitting socket bottom and give the pipe or fitting a 1/4 turn to evenly distribute the cement. Do not continue to rotate the pipe after it has hit the bottom of the fitting socket. A good joint will have sufficient cement to make a bead all the way around the outside of the fitting hub. The fitting will have a tendency to slide back while the cement is still wet so hold the joint together for about 15 seconds.

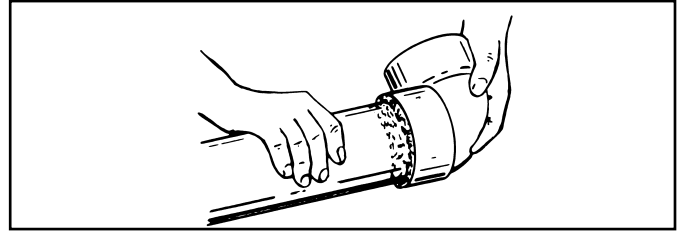

Figure 45

#### G. Cleanup and joint movement

Remove all excess cement from around the pipe and fitting with a dry cotton rag. This must be done while the cement is still soft.

The joint should not be disturbed immediately after the cementing procedure, and sufficient time should be allowed for proper curing of the joint. Exact drying time is difficult to predict because it depends on variables such as temperature, humidity and cement integrity. For more specific information, you should contact your solvent cement manufacturer.

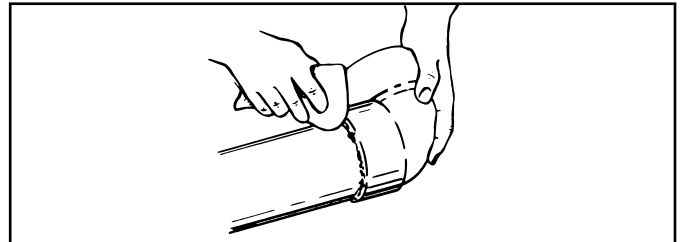

Figure 46

## INSTALLATION CHECKLIST

---

**Note:** Use and complete this checklist before lighting the heater. Correct any conditions that do not meet these instructions.

### Water Heater Location

- Centrally located with the water piping system. Located as close to gas piping and vent pipe system as possible.
- Located indoors and in a vertical position. Protected from freezing temperatures.
- Proper clearances from combustible surfaces maintained and not installed directly on a carpeted floor.
- Provisions made to protect the area from water damage. Metal drain pan installed and piped to an adequate drain.
- Installation area free of corrosive elements and flammable material.
- Sufficient room to service the water heater.
- Protected from moving vehicles.

### Gas Supply and Piping

- Gas supply is the same type as listed on the water heater data plate.
- Gas line equipped with shut-off valve, union and dirt leg
- Approved pipe joint compound used.
- Adequate pipe size and of approved material.
- Chloride-free soap and water solution or other approved means used to check all connections and fittings for possible gas leaks.

### Vent Pipe System

- Vent pipe and fittings of approved material.
- Acceptable size, length and number of elbows on exhaust vent system.
- Installed in accordance with prevailing provisions of local codes, or in the absence of such, the latest edition of “**National Fuel Gas Code**” **ANSI Z223.1 (NFPA 54)**.
- Horizontal piping slopes at an upward pitch of 1/8 in. rise per 4 ft. away from the water heater.
- Not obstructed in any way.

### Vent Termination

#### Horizontal

- 12 in. min. above grade/snow level.
- Away from corners, other vents, windows etc.

#### Vertical

- Exhaust vent termination 18 in. min. above roof/snow level.

### Water System Piping

- Temperature and Pressure relief valve properly installed with a discharge line run to an open drain and protected from freezing.
- All piping properly installed and free of leaks.
- Side taps plugged if not used for combo heating.
- Heater completely filled with water.
- Closed system pressure build-up precautions installed.

### Electrical Connections

- Unit connected to a dedicated 120V electrical supply.
- Proper polarity.
- Water heater properly grounded.
- Installed in accordance with prevailing provisions of local codes, or in the absence of such, the latest edition of the “**National Electrical Code**”, **NFPA 70**”.

**After all actions on checklist are checked/ completed, read the Lighting Instructions and proceed with lighting the heater.**

# LIGHTING INSTRUCTIONS

Read and understand these directions thoroughly before attempting to operate the water heater. Make sure the burner viewport is not missing or damaged. Make sure the tank is completely filled with water before operating the water heater. The gas control valve/thermostat has an "On/Off Switch" and must be turned on before the water heater is operational. Check the label on the front of the water heater near the gas control valve/thermostat for the correct gas. Do not start this water heater with any gas other than the one listed on the label. If you have any questions or doubts, consult the gas supplier or gas utility company. The following Lighting Instruction label appears on the front of the water heater.

This heater is equipped with a Honeywell gas control/thermostat and a hot-surface igniter. This control is a combination gas valve, thermostat and ignition controller for use on this power vented water heater. The valve contains a micro-controller that supervises the ignition sequence and monitors the temperature settings and operation of the heater. The controller also monitors the flammable vapor safety features of this heater.

**This heater is equipped with a hot-surface ignition system that automatically ignites the burner. Do not attempt to light this heater manually with a match or flame-producing device.**

## FOR YOUR SAFETY READ BEFORE LIGHTING





**WARNING:** If you do not follow these instructions exactly, a fire or explosion may result causing property damage, personal injury or loss of life.



**BEFORE OPERATING: ENTIRE SYSTEM MUST BE FILLED WITH WATER AND AIR PURGED FROM ALL LINES.**

- A. This appliance does not have a pilot. It is equipped with an ignition device which automatically lights the burner. **Do NOT try to light the burner by hand.**
- B. BEFORE OPERATING smell all around the appliance area for gas. Be sure to smell next to the floor because some gas is heavier than air and will settle on the floor.  
**WHAT TO DO IF YOU SMELL GAS:**
- Do not try to light any appliance.
  - Do not touch any electric switch; Do not use any phone in your building.
  - Immediately call your gas supplier from a neighbor's phone. Follow the gas suppliers instructions.
- C. If you cannot reach your gas supplier, call the fire department.
- C. Use only your hand to turn the gas control buttons. Never use tools. If the control buttons will not turn, don't try to repair them, call a qualified service technician. Force or attempted repair may result in a fire or explosion.
- D. Do not use this appliance if any part has been under water. Immediately contact a qualified installer or service agency to replace a flooded water heater. Do not attempt to repair the unit. It must be replaced!

## OPERATING INSTRUCTIONS

1.  STOP! Read the safety information above on this label.
2. Turn off all electric power to the appliance.
3. Turn the thermostat counter-clockwise  to the lowest setting.
4. Set the switch on the control to the "OFF" position.
5. Do not attempt to light manually.
6. Wait five (5) minutes to clear out any gas. If you then smell gas, STOP!  Follow "B" in the safety information above on this label. If you don't smell gas, go the next step.

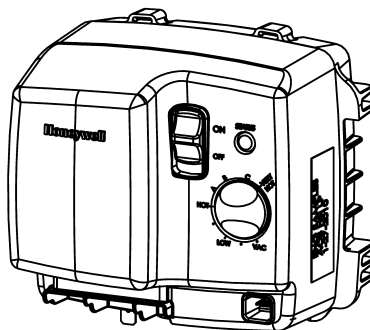

7. Turn on all electric power to the appliance.
8. Set the switch on the control to the "ON" position.
9. Turn thermostat to desired setting.

 **DANGER** Hotter water increases the risk of scald injury. Consult the instruction manual before changing temperature.

10. If the appliance will not operate, follow the instructions "To Turn Off Gas To Appliance" and call your service technician or gas supplier.

## TO TURN OFF GAS TO APPLIANCE

1. Turn the thermostat counter-clockwise  to the lowest setting.
2. Set the gas control switch to the "OFF" position.
3. Turn off electrical power to the appliance if service is to be performed.

323546-000

# OPERATING THE TEMPERATURE CONTROL SYSTEM

It is recommended that lower water temperatures be used to avoid the risk of scalding. It is further recommended, in all cases, that the water temperature be set for the lowest temperature which satisfies your hot-water needs. This will also provide the most energy efficient operation of the water heater.

Short repeated heating cycles caused by small hot-water uses can cause a temperature increase of the hot water by 20F° higher than the heater's temperature settings. If you experience this type of use you should consider using lower temperature settings to reduce scald hazards.

Should overheating occur or the gas supply fails to shut off, turn off the main manual gas shut off valve to the appliance (see Figure 1).

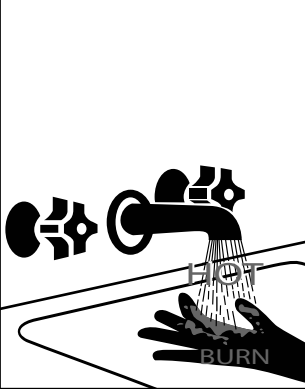
	<b>⚠ DANGER</b>
	<b>Water temperature over 125°F can cause severe burns instantly resulting in severe injury or death.</b>
	<b>Children, the elderly and the disabled and are at highest risk of scald injury.</b>
	<b>Feel water before bathing or showering.</b>
	<b>Temperature limiting devices such as mixing valves must be installed when required by codes and to ensure safe temperatures at fixtures.</b>

## HOT WATER CAN SCALD:

Water heaters are intended to produce hot water. Water heated to a temperature which will satisfy space heating, clothes washing, dish washing, and other sanitizing needs can scald and permanently injure you upon contact. Some people are more likely to be permanently injured by hot water than others. These include the elderly, children, the infirm or physically/mentally handicapped. If anyone using hot water from this heater fits into one of these groups or if there is a local code or state law requiring certain temperature water at the hot-water tap, then you must take special precautions. In addition to using the lowest possible temperature setting that satisfies your hot-water needs, a means such as a mixing valve, should be used at the hot-water taps used by these people or at the water heater. Mixing valves are available at plumbing supply or hardware stores (see Figure 8 & Figure 9). Follow manufacturer's instructions for installation of the valves. Before changing the factory setting on the thermostat, in this manual, see Table 4.

The water heater should be located in an area where the general public does not have access. If a suitable area is not available, a cover should be installed over the thermostat to prevent tampering.

This water heater is equipped with an adjustable thermostat to control water temperature (see Figure 47). Hot water temperatures required for automatic dishwasher and laundry use can cause scald burns resulting in serious personal injury and/or death. The temperature at which injury occurs varies with the person's age and time of the exposure. The slower response time of children, aged or disabled persons increases the hazards to them. Never allow small children to use a hot-water tap, or to draw their own bath water. Never leave a child or disabled person unattended in a bathtub or shower.

The hot setting shown on the dial is approximately 120°F. This is a good starting point to set the temperature.

Setting the water heater temperature at 120°F will reduce the risk of scalds. Some states require settings at specific lower temperatures.

The thermostat settings on the gas control valve are shown in Figure 47.

The water temperature setting was factory set at the lowest (VAC) temperature setting.

## GAS CONTROL VALVE/THERMOSTAT

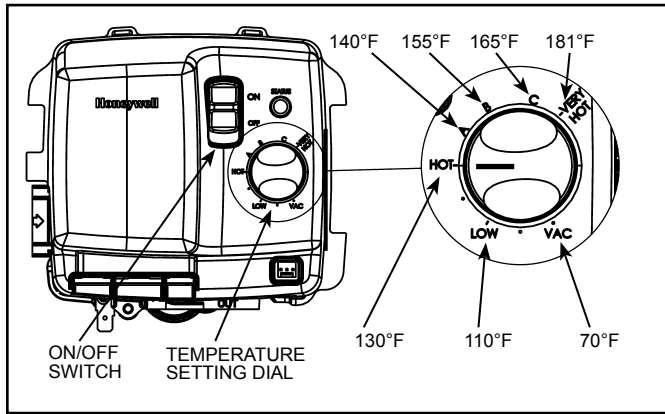

Figure 47

Temperature Dial Setting	Approximate Temperature °F	Time to induce a 2nd and 3rd Degree burn to adult skin
VERY HOT	181	Less than 1 second
C	165	Less than 1 second
B	155	About 1.5 seconds
A	140	Less than 5 seconds
HOT	130	More than 30 seconds
LOW	110	Normal shower temp
VAC	70	N/A

Table 4

**Note:** The temperatures indicated are approximates. The actual temperature of the heated water may vary. The Vacation Setting (VAC) sets the controller at approximately 70°F. This setting is recommended when the water heater is not in use for a long period of time. This effectively turns the controller temperature setting down to a temperature that prevents the water in the water heater from freezing while still conserving energy.



# FOR YOUR INFORMATION

## START UP CONDITIONS

### Condensate

Whenever the water heater is filled with cold water, some condensate will form while the burner is ON. A water heater may appear to be leaking when in fact the water is condensate. This usually happens when:

- A new water heater is filled with cold water for the first time.
- Burning gas produces water vapor in water heaters, particularly high efficiency models where flue temperatures are lower.
- Large amounts of hot water are used in a short time and the refill water in the tank is very cold.

Moisture from the products of combustion condense on the cooler tank surfaces and form drops of water which may fall onto the burner or other hot surfaces to produce a “sizzling” or “frying” noise.

Because of the suddenness and amount of water, condensate water maybe diagnosed as a “tank leak”. After the water in the tank warms up (about 1-2 hours), the condition should disappear.

Do not assume the water heater is leaking until there has been enough time for the water in the tank to warm up.

An undersized water heater will cause more condensation. The water heater must be sized properly to meet the family’s demands for hot water including dishwashers, washing machines and shower heads.

Excessive condensate maybe noticed during the winter and early spring months when incoming water temperatures are at their lowest.

Good venting is essential for a gas fired water heater to operate properly as well as to carry away products of combustion and water vapor (see also “Condensate” section).

### Smoke/odor

It is not uncommon to experience a small amount of smoke and odor during the initial start-up. This is due to burning off of oil from metal parts, and will disappear in a short while.

### Strange sounds

Possible noises due to expansion and contraction of some metal parts during periods of heat-up and cool-down do not necessarily represent harmful or dangerous conditions. Condensation causes sizzling and popping within the burner area during heating and cooling periods and should be considered normal. See “Condensate” section in this manual.

## OPERATIONAL CONDITIONS

### Smelly water

Each water heater contains at least one anode rod for corrosion protection of the tank. Certain water conditions will cause a reaction between this rod and the water. The most common complaint associated with the anode rod is one of a “rotten egg smell” in the hot water. The smell is a result of four factors which must all be present for the odor to develop:

- A concentration of sulfate in the supply water.
- Little or no dissolved oxygen in the water.
- A sulfate reducing bacteria which has accumulated within the water heater (this harmless bacteria is nontoxic to humans).
- An excess of active hydrogen in the tank. This is caused by the corrosion protective action of the anode.

Smelly water may be eliminated or reduced in some water heater models by replacing the anode(s) with one of less active material, and then chlorinating the water heater tank and all water lines. Contact the local water heater supplier or service agency for further information concerning an Anode Replacement Kit and this chlorination treatment.

If the smelly water persists after the anode replacement and chlorination treatment, we can only suggest that chlorination or aeration of the water supply be considered to eliminate the water problem.

**Do not remove the anode leaving the tank unprotected. By doing so, all warranty on the water heater tank is voided.**

## “AIR” IN HOT-WATER FAUCETS

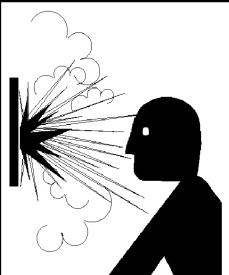
	<b>⚠ WARNING</b>
	<b>Explosion Hazard</b> <ul style="list-style-type: none"><li>• Flammable hydrogen gases may be present.</li><li>• Keep all ignition sources away from faucet when turning on hot water.</li></ul>

**HYDROGEN GAS:** Hydrogen gas can be produced in a hot-water system that has not been used for a long period of time (generally two weeks or more). Hydrogen gas is extremely flammable and explosive. To prevent the possibility of injury under these conditions, it is recommended that the hot-water faucet, located farthest away, be opened for several minutes before any electrical appliances which are connected to the hot-water system are used (such as a dishwasher or washing machine). If hydrogen gas is present, there will probably be an unusual sound similar to air escaping through the pipe as the hot-water faucet is opened. There must be no smoking or open flame near the faucet at the time it is open.

# PERIODIC MAINTENANCE

## GENERAL UPKEEP

Make it a habit to look around the heater, the vent piping, and the hot and cold water pipes. Do not allow any material to be piled up against the heater. Do not place any object on top of the vent pipes.

Every 3 - 6 months or as necessary:

- Clean lint from blower, top of heater.

Once per year:

- Inspect the Vent System.
- Burner Operation and Inspection.
- Combustion Chamber for scaling or sooting.
- Temperature-Pressure Relief Valve Test.
- Anode Rod Inspection.
- Flush a pail of water from the heater drain valve, once per year.

If any deficiencies or abnormalities are encountered during these inspections call a qualified service technician.

## VENTING SYSTEM INSPECTION

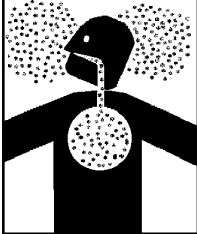
 <b>WARNING</b>	
<b>Breathing Hazard - Carbon Monoxide Gas</b>	
	<ul style="list-style-type: none"><li>• Flue gases may escape if vent pipe is not properly connected.</li><li>• Be alert for obstructed, sooted or deteriorated vent system to avoid serious injury or death.</li><li>• Do not store corrosive chemicals in vicinity of water heater.</li><li>• Chemical corrosion of flue and vent system can cause serious injury or death.</li><li>• Analyze the entire vent system to make sure that condensate will not become trapped in a section of vent pipe and therefore reduce the open cross sectional area of the vent.</li></ul>
<b>Breathing carbon monoxide can cause brain damage or death. Always read and understand instruction manual.</b>	

At least once a year a visual inspection should be made of the venting system. You should look for:

- Obstructions which could cause improper venting. The combustion, dilution and ventilation air flow must not be obstructed.
- Damage or deterioration which could cause improper venting or leakage of combustion products.

Be sure the vent piping is properly connected to prevent escape of dangerous flue gasses which could cause deadly asphyxiation.

Obstructions and deteriorated vent systems may present serious health risk or asphyxiation.

Chemical vapor corrosion of the flue and vent system may occur if air for combustion contains certain chemical vapors. Spray can propellants, cleaning solvents, refrigerator and air conditioner refrigerants, swimming pool chemicals, calcium and sodium chloride, waxes, bleach and process chemicals are typical compounds which are potentially corrosive.

If after inspection of the vent system you found sooting or deterioration, something is wrong. Call the local gas utility to correct the problem and clean or replace the flue and venting before resuming operation of the water heater.

## BLOWER MAINTENANCE

Inspect the top of the heater and around the ventilation openings of the blower motor and the rear blower dilution air intakes for any lint and dust that may have accumulated. Depending on the location of the heater, significant quantities of lint may accumulate. The lint may obstruct the free flow of air to the motor, and cause the motor and blower to run hotter than normal (see Figure 48).

To clean any dust and lint, proceed as follows:

1. Unplug the water heater.
2. Using a nylon bristled paint or toothbrush, brush away any lint. Pick up the lint with a cloth.

Better results can be achieved by using the small brush on a vacuum cleaner to remove all lint and dust which have accumulated on top of the heater, the louvres of the air intake snorkel, the motor ventilation openings and the rear blower dilution air intakes.

**Important:** Do not insert any foreign object into the ventilation openings of the motor.

## CLEANING THE BLOWER.

In dusty and contaminated air conditions, the interior of the blower and the blower wheel may require periodic cleaning. This is often indicated by nuisance failures of the air pressure switch or the high limit temperature control. A collection of dust or debris on the rear blower dilution air intakes can also indicate reduced blower capacity. To clean the inside of the blower assembly and the blower wheel requires the removal of the blower/motor from the mounting plate located on the top of the heater. Tools required include an 11/32" nut driver, small (1") paint brush, toothbrush and vacuum cleaner.

1. Turn the thermostat on the gas control to the lowest setting. If the heater is running, wait for it to shut down (see Figure 47).
2. Turn the gas control switch to the "OFF" position.
3. Disconnect the electrical power to the water heater from the wall outlet.
4. Disconnect the vent piping from the top of the blower. Loosen the lower gear clamp that holds the rubber coupling to the blower (see Figure 48).
5. Remove and retain the (4) 11/32" nuts located on the back of the blower with the nutdriver (see Figure 41 & Figure 48).
6. Holding the blower motor and the blower housing, pull the assembly forward to disengage it from the mounting plate. The blower will still be connected to the junction box so exercise care not to stress the wiring.

7. Accessing the blower wheel through the outlet, use the paint brush to brush off the outer edge of the blower wheel to dislodge any dirt stuck on the blades and the inside of the housing. Rotate the wheel until all blades are clear. **Note:** The wheel is a balanced component. Do not bend, dent or distort the blades as this can upset the wheel balance and affect the blower operation. Vacuum out the loosened dirt.
8. Accessing the inside of the blower wheel through the rear of the housing, gently brush off the inside of the blades using the toothbrush. Again, take care not to distort the blades. Rotate the wheel until all blades are cleaned and vacuum the debris. Do not remove any of the balancing chips attached to the blades.
9. Inspect the flue collector hood (still attached to the heater) and vacuum out the dust and debris that may have accumulated.
10. With all parts cleaned and the blower wheel turning freely, reinstall the blower to the mounting plate aligning the (4) studs and pushing tight against the mounting plate.
11. Reinstall the (4) 11/32" nuts and tighten securely. All (4) nuts must be in place and secure to safely operate the blower.
12. Reattach the vent piping and coupling to the top of the blower, tighten the bottom gear clamp and ensure the piping is secure.
13. With all components clean and secure, reconnect the electrical power to the heater.
14. Reset the thermostat to the desired temperature setting and turn the gas control switch back to the "ON" position. **Note:** If the water in the heater is hot, the unit will wait to operate until there is a need for more hot water.

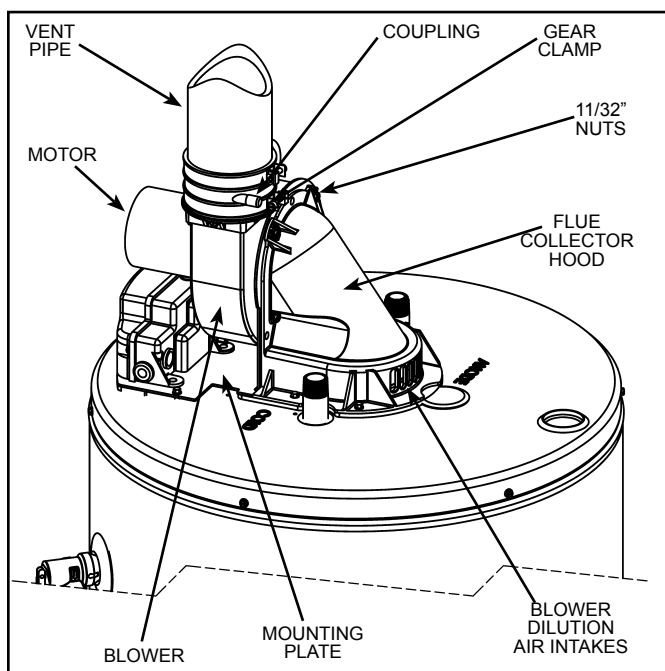

**Figure 48**

## **BURNER OPERATION AND INSPECTION**

Flood damage to a water heater may not be readily visible or immediately detectable. However, over a period of time a flooded water heater will create dangerous conditions which can cause death, serious bodily injury, or property damage. Contact a qualified installer or service agency to replace a flooded water heater. Do not attempt to repair the unit! It must be replaced!

At least once a year a visual inspection should be made of the main burner and the hot surface igniter assembly for proper flame characteristics and ignition sequences. This can be done by removing the outer door and viewing the main burner operation through the viewport on the inner door (see Figure 49). The main burner should provide complete combustion of gas, ignite rapidly, give reasonably quiet operation, and cause no excessive flame lifting from the burner ports. If the proper flame characteristics are not evident (see Figure 50), make sure that the flow of combustion and ventilation air is not blocked.

You should also check for sooting. Soot is not normal and will impair proper combustion. A visual inspection of the main burner and hot surface igniter should also be done at least once a year (see Figure 49).

Soot build-up indicates a problem that requires correction before further use. Turn "OFF" gas to water heater by unplugging the power cord and leave off until repairs are made. Failure to correct the cause of the sooting can result in a fire causing death, serious injury, or property damage.

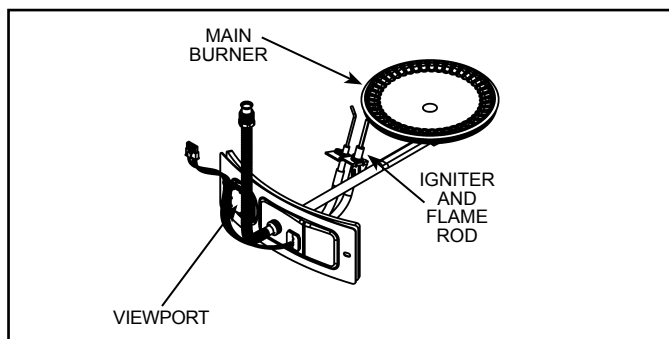

**Figure 49**

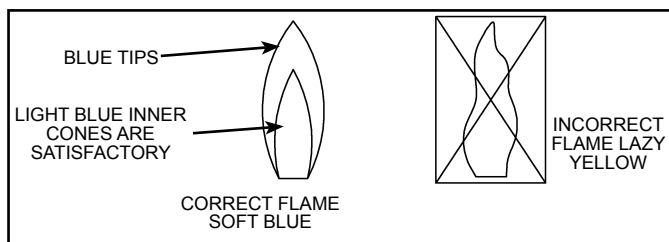



**Figure 50**

## COMBUSTION CHAMBER AND BURNER CLEANING

In the event your burner or burner air openings require cleaning, Call your service agency to remove and clean the burner and correct the problem that required the burner to be cleaned.

## HOUSEKEEPING

 <b>DANGER</b>	
	<b>Fire and Explosion Hazard</b>
	<ul style="list-style-type: none"><li>• Do not obstruct combustion air openings at the rear of the water heater.</li><li>• Do not use or store flammable vapor products such as gasoline, solvents or adhesives in the same room or area near water heater or other appliance.</li><li>• Can cause serious injury or death.</li></ul>

### INSTALLED IN SUITABLE AREA:

To ensure sufficient ventilation and combustion air supply, proper clearances from the water heater must be maintained. See “Locating The New Water Heater” section. Combustible materials such as clothing, cleaning materials, or flammable liquids, etc. must not be placed against or adjacent to the water heater which can cause a fire.

## ANODE ROD INSPECTION

Each water heater contains at least one anode rod, which will slowly deplete (due to electrolysis) prolonging the life of the water heater by protecting the glass-lined tank from corrosion. Adverse water quality, hotter water temperatures, high hot water usage, hydronic heating devices and water softening methods can increase the rate of anode rod depletion. Once the anode rod is depleted, the tank will start to corrode eventually developing a leak.

Certain water conditions will cause a reaction between the anode rod and the water. The most common complaint associated with the anode rod is a “rotten egg smell” produced from the presence of hydrogen sulfide gas dissolved in the water. **Important:** Do not remove this anode rod permanently as it will void any warranties. A special anode rod may be available if water odor or discoloration occurs. **Note:** This anode rod may reduce but not eliminate water odor problems. The water supply system may require special filtration equipment from a water conditioning company to successfully eliminate all water odor problems.

Artificially softened water can be exceedingly corrosive because the process substitutes sodium ions for magnesium and calcium ions. The use of an excessively soft water may decrease the life of the water heater tank.

The anode rod should be inspected after a maximum of three years and annually thereafter until the condition of the anode rod dictates its replacement. **Note:** Artificially softened water requires the anode rod to be inspected annually.

The following are typical (but not all) signs of a depleted anode rod:

- The majority of the anode rod’s diameter is less than 3/8 in..
- Significant sections of the support wire (approx. 1/3 or more of the anode rod’s length) are visible (see Figure 51).

If the anode rod shows signs of either or both it should be replaced. **Note:** Whether re-installing or replacing the anode rod, check for any leaks and immediately correct if found.

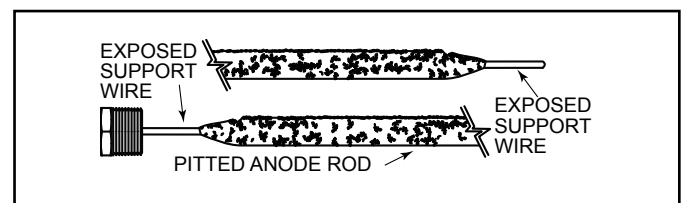

Figure 51

## ANODE ROD

**Important:** Use only factory authorized replacement parts. If you lack the necessary skills to properly perform the installation, you should not proceed, but get help from a qualified service technician.

- Tools required:
- Ratchet with 1-1/16” Socket
- Pliers
- Teflon® Tape or an approved pipe sealant

### Removing Anode Rod:

1. Set the gas control valve/thermostat to its lowest setting by turning the knob counter-clockwise to the VAC point (see Figure 47). If the water heater is running, wait for it to shut down.
2. Turn gas control switch to the “OFF” position.
3. Disconnect the electrical power to the water heater from the wall outlet.
4. Shut off the incoming water supply to the water heater and open a nearby hot-water faucet to depressurize the water tank.
5. Connect a hose to the drain valve and terminate it to adequate drain or to the exterior of the building. Open the drain valve and allow at least 5 gallons of water to drain from the tank. Close drain and remove hose.
6. Remove the anode cap on top of the heater and remove just enough insulation so you can access to the anode head (see Figure 52). Keep the anode cap in a safe place for reinstallation later.
7. Remove the anode rod by using a ratchet and a 1-1/16” socket turning counter-clockwise (see Figure 52).

### Installing Anode Rod:

1. Use Teflon® tape or an approved pipe sealant on threads of the new anode rod.
2. Place the anode rod in the spud (top of the tank) and turn clockwise until the threads are hand tight. Using a ratchet and 1-1/16" socket tighten down water tight.
3. Open a nearby hot-water faucet to purge air from the water line. Open the incoming water supply and fill water heater tank completely (**Note:** To assure the water heater tank is full, keep the hot-water faucet open for 3 minutes after a constant flow of water is obtained).
4. Turning off the hot-water faucet, check for water leaks around anode rod and immediately correct any if found.
5. Reinstall the insulation and anode cap which were removed in step 6 of removal instructions.
6. With all components clean and secure, reconnect the electric power to the heater.
7. Reset the thermostat to the desired temperature setting and turn the gas control switch back to the "ON" position (see Figure 47).

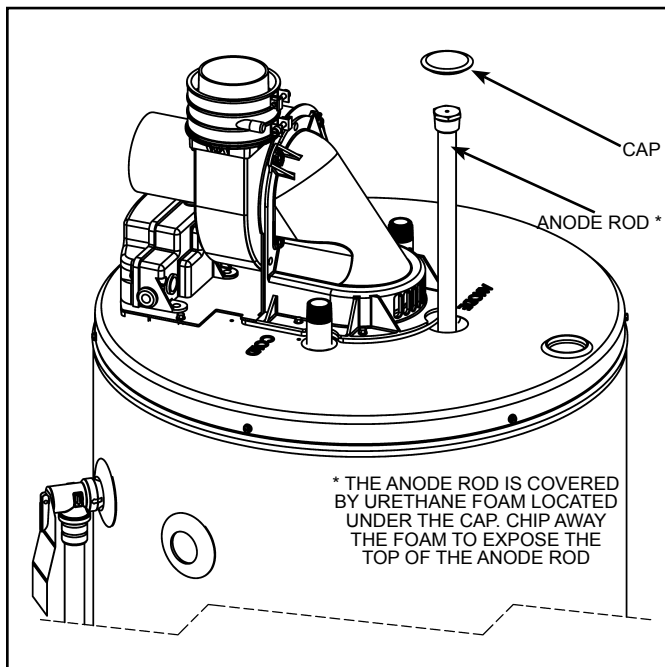
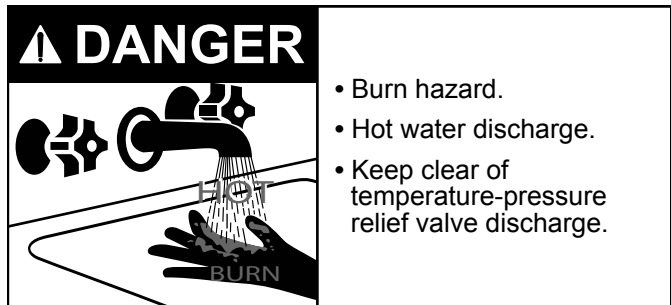

Figure 52

### TEMPERATURE-PRESSURE RELIEF VALVE TEST



It is recommended that the temperature-pressure relief valve be checked to ensure it is in operating condition at least once a year.

When checking the temperature-pressure relief valve operation, make sure that (1) no one is in front of or around the outlet of the T&P valve discharge line, and (2) that water discharge will not cause any property damage, as water may be extremely hot. Use care when operating valve as the valve may be hot.

To check the relief valve, lift lever at the end of valve several times (see Figure 53). The valve should seat properly and operate freely.

If after manually operating the valve, it fails to completely reset and continues to release water, immediately close the cold-water inlet to the water heater and drain the water heater, see "Draining And Flushing" section. Replace the T&P valve with a properly rated/sized new one, see "Temperature-Pressure Relief Valve" for instructions on replacement.

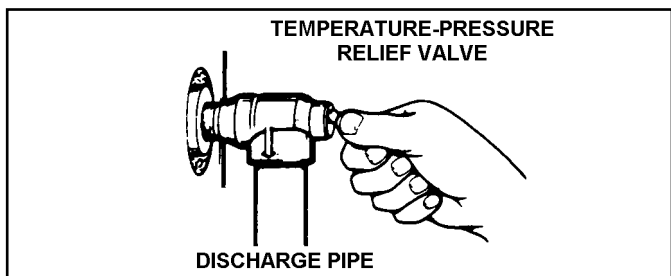
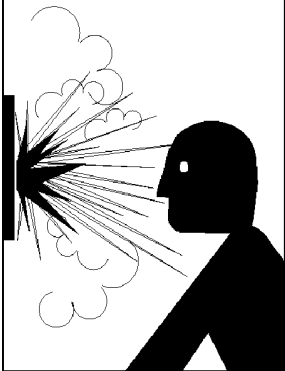

Figure 53

If the Temperature-Pressure Relief Valve on the water heater weeps or discharges periodically, it may be due to thermal expansion.

**Note:** Excessive water pressure is the most common cause of temperature-pressure relief valve leakage. Excessive water system pressure is most often caused by "thermal expansion" in a "closed system." See "Closed Water Systems" and "Thermal Expansion" sections of this manual. The T&P valve is not intended for the constant relief of thermal expansion.

Temperature-pressure relief valve leakage due to pressure build up in a closed system that does not have a thermal expansion tank installed is not covered under the Limited Warranty. Thermal expansion tanks must be installed on all closed water systems.

<b>⚠ WARNING</b>	
	<b>Explosion Hazard</b>
	<ul style="list-style-type: none"> <li>• Temperature-pressure relief valve must comply with ANSI Z21.22-CSA4.4 and ASME code.</li> <li>• Properly sized temperature-pressure relief valve must be installed in opening provided.</li> <li>• Do not plug, block, or cap the discharge line.</li> <li>• Failure to follow this warning can result in excessive tank pressure, serious injury or death.</li> </ul>

### **DRAINING AND FLUSHING**

Periodic draining and cleaning of sediment from the tank maybe necessary. It is recommended that the tank be drained and flushed every 6 months to remove sediment which may build up during operation. The water heater should be drained if being shut down during freezing temperatures. See “Typical Installation” section in this manual for location of the water heater components described below.

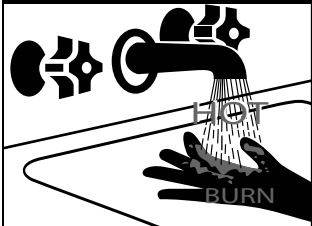
<b>⚠ DANGER</b>	
	<ul style="list-style-type: none"> <li>• Burn hazard.</li> <li>• Hot water discharge.</li> <li>• Keep hands clear of drain valve discharge.</li> </ul>

### **To drain the water heater storage tank:**

1. Turn “OFF” the electrical supply to the water heater.
2. Turn “OFF” the gas supply at the Main Gas shut-off Valve if the water heater is going to be shut down for an extended period.
3. CLOSE the cold-water inlet valve to the water heater.
4. OPEN a nearby hot-water faucet and leave open to allow for draining.
5. Connect a hose to the drain valve and terminate to an adequate drain.

**Note:** If the water heater is going to be shut down and drained for an extended period, the drain valve should be left open with hose connected allowing water to terminate to an adequate drain.

6. Close the water heater drain valve when all water in the storage tank has drained.
7. Follow instructions in the “Filling The Water Heater” section.
8. Turn “ON” the gas supply at the main gas shut-off valve.
9. Follow the lighting instructions on the label or see “Lighting Instructions” to restart the water heater.

### **To flush the water heater storage tank:**

1. Turn “OFF” the electrical supply to the water heater.
2. Ensure the cold-water inlet valve is open.
3. Connect a hose to the drain valve and terminate it to an adequate drain.
4. Ensure the drain hose is secured before and during the entire flushing procedure. Flushing is performed with system water pressure applied to the water heater.
5. Open the water heater drain valve to flush the storage tank. **Caution:** Water will be hot.
6. Flush the water heater storage tank to remove sediment and allow the water to flow until it runs clean.
7. Close the water heater drain valve when flushing is completed.
8. Remove the drain hose.
9. Ensure the heater is full of water.
10. Turn “ON” electrical supply to place water heater back in operation and follow the lighting instructions.
11. Allow the water heater to complete several heating cycles to ensure it is operating properly.

**Caution:** Do not turn on power to the water heater unless the tank is full. Open a hot-water faucet and allow the water to run until the air is purged and the water flows uninterrupted from the faucet.

**Important:** When operating a cold tank, condensation can occur and drip on the burner. This should not be confused with a tank leak.

# LEAKAGE CHECKPOINTS

## SERVICE

If a condition persists or you are uncertain about the operation of the water heater contact a service agency. Use this guide to check a “leaking” water heater. Many suspected “leakers” are not leaking tanks. Often the source of the water can be found and corrected.

If you are not thoroughly familiar with gas codes, your water heater and safety practices, contact your gas supplier or qualified installer to check the water heater.

Ensure the venting is properly attached and secured.

Never use this water heater unless it is completely filled with water. To prevent damage to the tank, the tank must be filled with water. Water must flow from the hot-water faucet before turning “ON” gas to the water heater.

- A. Water at the blower assembly is water vapor which has condensed out of the combustion products. This is caused by a problem in the vent. A drainage port is included at the vent pipe connection. Contact the gas utility.
- B. \*Condensation may be seen on pipes in humid weather or pipe connections may be leaking.
- C. \*The anode rod fitting may be leaking.
- D. Small amounts of water from temperature-pressure relief valve may be due to thermal expansion or high water pressure in your area.
- E. \*The temperature-pressure relief valve may be leaking at the tank fitting.
- F. Water from a drain valve may be due to the valve being slightly opened.
- G. \*The drain valve may be leaking at the tank fitting.
- H. Combustion products contain water vapor which can condense on the cooler surfaces of the tank. Droplets form and drip onto the burner. This is common at the time of start-up after installation and when incoming water is cold.
- I. Water in the water heater bottom may be from condensation, loose connections, or the relief valve. DO NOT replace the water heater until a full inspection of all possible water sources is made and necessary corrective steps taken.

Leakage from other appliances, water lines, or ground seepage should also be checked.

- \* To check where threaded portion enters tank, insert cotton swab between jacket opening and fitting. If cotton is wet, follow “Draining And Flushing” instructions in the “Periodic Maintenance” section and then remove fitting. Put pipe dope or Teflon tape on the threads and replace. Then follow “Filling The Water Heater” instructions in the “Installing The New Water Heater” section.

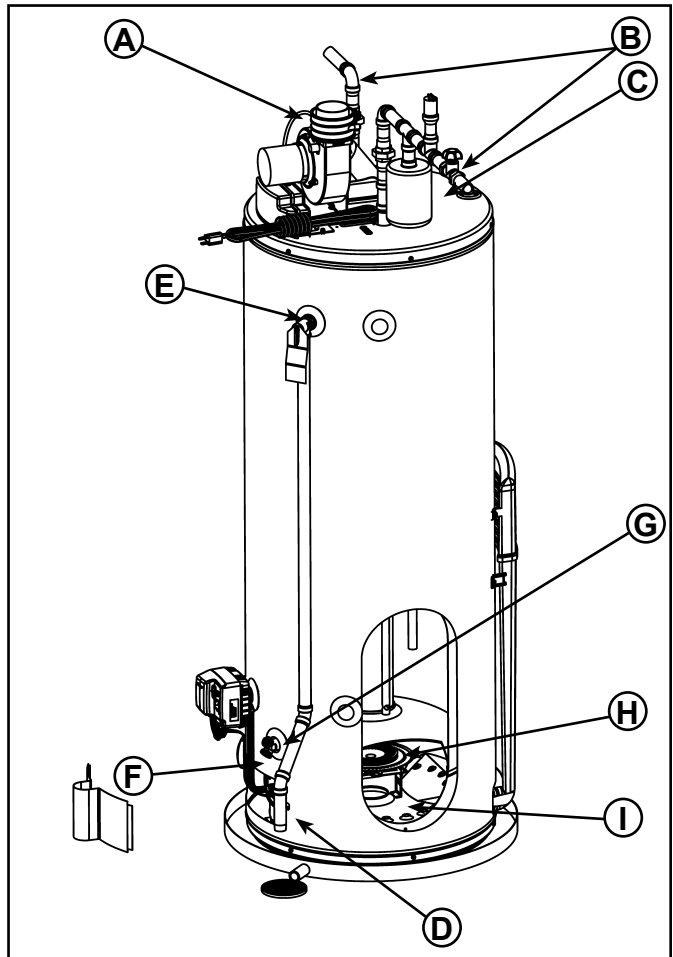
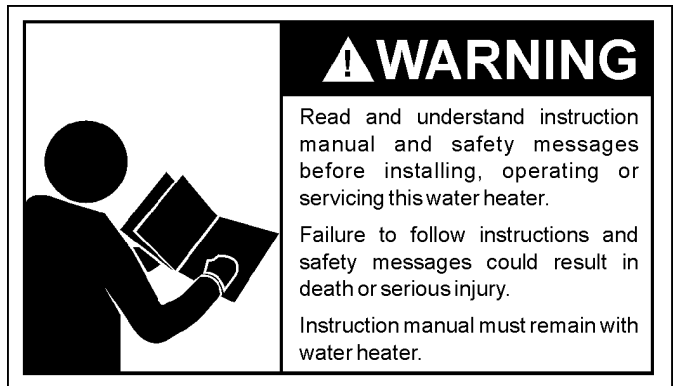

Figure 54

# REFERENCE PARTS LISTING

Replacement parts may be ordered through your plumber or the local distributor. When ordering replacement parts, always have the following information ready:

- Model, Serial and Product number
- Type of gas
- Item number
- Parts description

- 1 Vent Termination Elbow with Rodent Screen
- 2 \*Vent Pipe
- 3 \*Vent Pipe Coupling (if required)
- 4 CPVC Vent Pipe (5 ft. supplied)
- 5 \*CPVC Vent Pipe Elbow (long radius)
- 6 Gear Clamp (see Figure 6) (see also **Figure 60**)
- 7 T&P Valve
- 8 \*\*Combo Heating System Supply Outlet (Optional)
- 9 Cold-Water Inlet Nipple/Diptube
- 10 \* Discharge Pipe
- 11 Gas Control Valve/Thermostat (Honeywell)
- 12 Gas Valve Electronic Control Module And Cover (Honeywell)

- 13 \*\*Combo Heating System Return Inlet (Optional)
- 15 Drain Valve
- 16 Outer Gas Door
- 17 Manifold Door Assembly (behind outer door) (see Figure 3 (NG) or Figure 4 (LP)) (see also **Figure 57**)
- 18 \*Floor Drain
- 19 \*Metal Drain Pan
- 20 Flammable Vapor Sensor (under cover) (see Figure 5) (see also **Figure 59**)
- 26 Baffle Assembly
- 28 Blower with Power Cord (see Figure 6)
- 29 \*Rubber Coupling (see Figure 6) (see also **Figure 60**)
- 32 Hot-Water Outlet Nipple
- 33 Anode (under cap)
- 34 Air Inlet Snorkel
- 35 Flue Collector
- 37 Aluminum Burner (see Figure 3) (see also **Figure 57**)
- 38 Gas Orifice (see Figure 3) (see also **Figure 57**)
- 39 Gas Manifold (see Figure 3) (see also **Figure 57**)

- 40 Hot-Surface Igniter (see Figure 3) (see also **Figure 57**)
  - 41 Manifold Door Gasket (see Figure 3) (see also **Figure 57**)
  - 42 Manifold Door (see Figure 3) (see also **Figure 57**)
  - 43 Two Piece Grommet With Clip (see Figure 3) (see also **Figure 57**)
  - 44 Viewport (see Figure 3) (see also **Figure 57**)
  - 45 Flame Sensor Rod (see Figure 3) (see also **Figure 57**)
  - 46 Stainless Steel Burner (see Figure 4) (see also **Figure 58**)
  - 47 Air Switch (inside box) (see Figure 6) (see also **Figure 60**)
  - 48 Air Tubing (see Figure 6) (see also **Figure 60**)
  - 49 Blower High Limit Switch (see Figure 6) (see also **Figure 60**)
  - 50 Junction Box Cover (see Figure 6) (see also **Figure 60**)
- \* parts not supplied with the water heater  
 \*\* The side recirculation loop connections may not be used as the primary water inlet and outlet connections. See "Combo Heating Inlet And Outlet Side Taps".

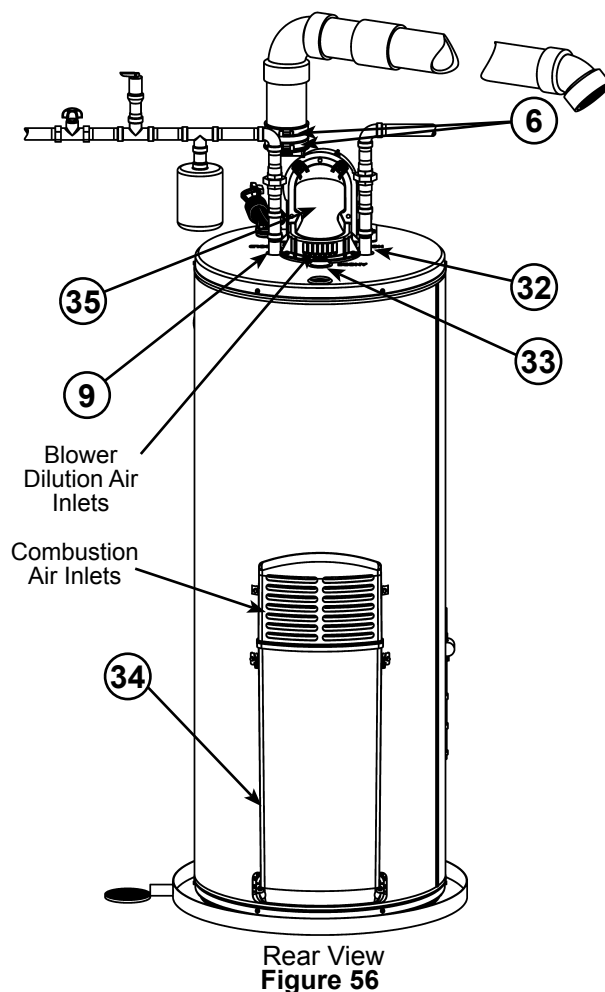
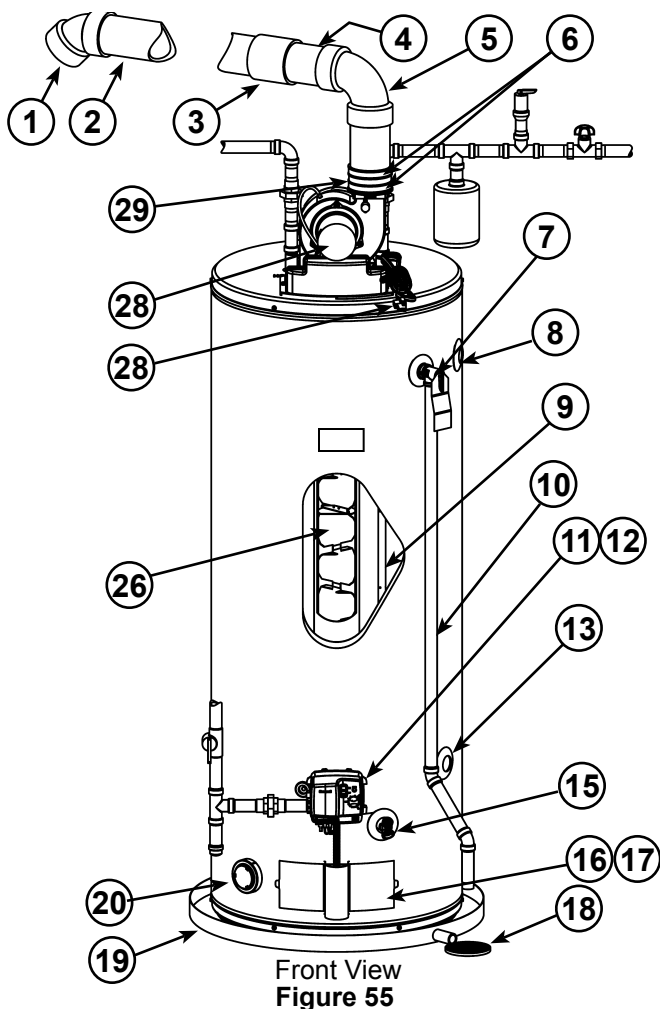



Natural gas main burner with igniter assembly (item 17 in Figure 55).

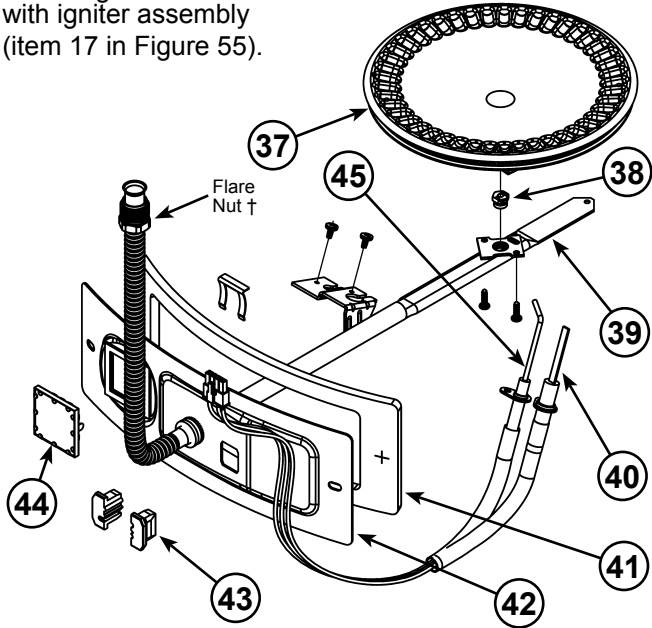

Figure 57

Propane (LP) main burner with igniter assembly (item 17 in Figure 55).

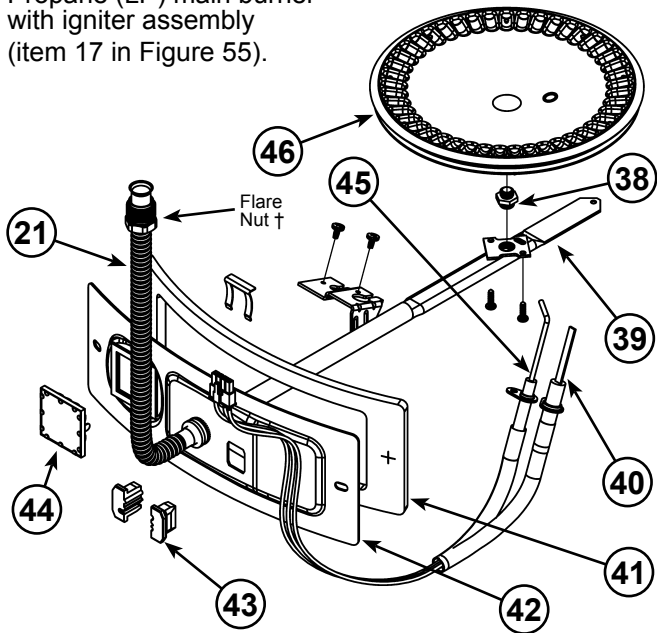

Figure 58

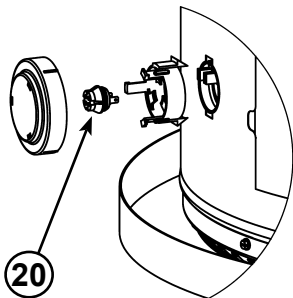

Figure 59

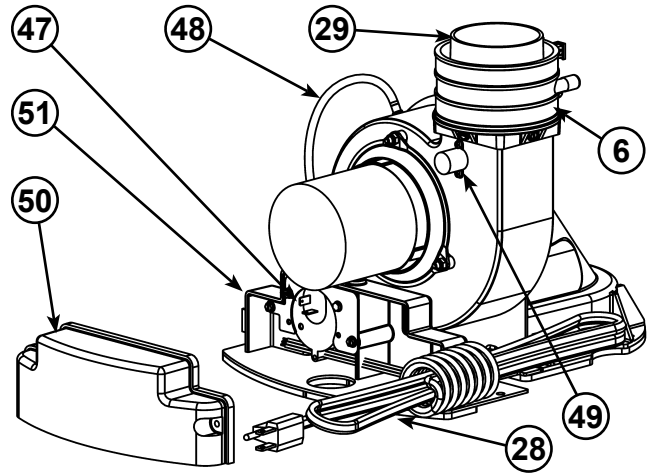

Figure 60

**Note:** † For Natural gas models the Flare Nut has Right-hand thread. For Propane models the Flare Nut has Left-hand thread.

# TROUBLESHOOTING GUIDELINES

These guidelines should be utilized by a qualified service agent.

PROBLEM	POSSIBLE CAUSE(S)	CORRECTIVE ACTION
BURNER FLAME TOO HIGH	<ol style="list-style-type: none"> <li>Air inlets blocked</li> <li>Insufficient secondary air</li> <li>Orifice too large</li> </ol>	<ol style="list-style-type: none"> <li>Unblock inlet air openings</li> <li>Provide ventilation to water heater</li> <li>Replace with correct orifice</li> </ol>
FLAME BURNS AT ORIFICE	<ol style="list-style-type: none"> <li>Low gas pressure</li> <li>Defective gas control valve/thermostat</li> </ol>	<ol style="list-style-type: none"> <li>Check with gas utility company</li> <li>Replace gas control valve/thermostat</li> </ol>
INSUFFICIENT HOT WATER	<ol style="list-style-type: none"> <li>Low gas pressure</li> <li>Orifice too small</li> <li>Thermostat set too low</li> <li>Gas control error codes</li> <li>Sediment or lime in tank</li> <li>Water heater too small</li> <li>Wrong piping connections</li> <li>Leaking faucets</li> <li>Wasted hot water</li> <li>Long runs of exposed piping</li> <li>Hot-water piping in outside wall</li> </ol>	<ol style="list-style-type: none"> <li>Check with gas utility company</li> <li>Replace with correct orifice (see rating plate)</li> <li>Turn temperature knob to higher setting</li> <li>Refer to gas control error codes</li> <li>Drain/flush-provide water treatment if needed</li> <li>Install adequate heater</li> <li>Correct piping: dip tube must be in cold inlet</li> <li>Repair faucets</li> <li>Advise customer</li> <li>Insulate piping</li> <li>Insulate piping</li> </ol>
WATER IS TOO HOT	<ol style="list-style-type: none"> <li>Thermostat is set too high</li> <li>Defective gas control valve/thermostat</li> </ol>	<ol style="list-style-type: none"> <li>Turn temperature knob to lower setting</li> <li>Replace the gas control valve/thermostat</li> </ol>
SLOW HOT WATER RECOVERY	<ol style="list-style-type: none"> <li>Insufficient air/ flue blockage</li> <li>Low gas pressure</li> <li>Orifice too small</li> <li>Thermostat set too low</li> <li>Heater too small</li> <li>Wrong piping connection</li> <li>Wasted hot water</li> <li>Flue clogged</li> <li>Air inlets blocked</li> </ol>	<ol style="list-style-type: none"> <li>Provide ventilation to water heater. Check flue way, flue baffle and burner</li> <li>Check with gas utility company</li> <li>Replace with correct orifice (see rating plate)</li> <li>Turn temperature knob to higher setting</li> <li>Install adequate heater</li> <li>Correct piping-dip tube must be in cold inlet</li> <li>Advise customer</li> <li>Clean flue, locate source and correct</li> <li>Unblock inlet air openings</li> </ol>
DRIP FROM RELIEF VALVE	<ol style="list-style-type: none"> <li>Pressure build-up</li> <li>Heater stacking</li> <li>Closed water system</li> <li>Improperly seated valve</li> </ol>	<ol style="list-style-type: none"> <li>Use a pressure-reducing valve and relief valve</li> <li>Lower the thermostat setting</li> <li>See "Thermal Expansion" section</li> <li>Check Relief valve for proper operation (Do Not plug T&amp;P valve)</li> </ol>
GAS CONTROL VALVE/ THERMOSTAT FAILS TO SHUT OFF	<ol style="list-style-type: none"> <li>Defective gas control valve/thermostat</li> </ol>	<ol style="list-style-type: none"> <li>Replace gas control valve/thermostat</li> </ol>
SMELLY WATER	<ol style="list-style-type: none"> <li>Sulfides in water supply</li> <li>Bacteria in water supply</li> <li>Incompatible anode</li> </ol>	<ol style="list-style-type: none"> <li>Chlorination procedure</li> <li>Chlorination procedure</li> <li>Replace with anode appropriate for water conditions</li> </ol>

<b>PROBLEM</b>	<b>POSSIBLE CAUSE(S)</b>	<b>CORRECTIVE ACTION</b>
CONDENSATION	<ol style="list-style-type: none"> <li>1. Filling the new water heater for the first time</li> <li>2. Moisture from the products of combustion</li> <li>3. Water dripping from blower assembly</li> <li>4. Undersized water heater</li> </ol>	<ol style="list-style-type: none"> <li>1. Normal operation: the condensation should disappear after heater warms up</li> <li>2. Normal operation: the condensation should disappear in time</li> <li>3. Install condensate hose to drain port on the rubber coupling</li> <li>4. Install adequate heater</li> </ol>
COMBUSTION ODORS	<ol style="list-style-type: none"> <li>1. Air inlets blocked</li> <li>2. Insufficient air</li> <li>3. Flue clogged</li> <li>4. Heater installed in a confined area</li> <li>5. House too tight</li> </ol>	<ol style="list-style-type: none"> <li>1. Unblock inlet air openings</li> <li>2. Provide fresh air ventilation to the water heater</li> <li>3. Clean, locate source and correct</li> <li>4. Provide fresh air ventilation to the water heater</li> <li>5. Provide fresh air ventilation to the water heater</li> </ol>
SMOKING AND CARBON FORMATION	<ol style="list-style-type: none"> <li>1. Air inlets blocked</li> <li>2. Insufficient air</li> <li>3. Low gas pressure</li> <li>4. Orifice too large</li> <li>5. Flue clogged</li> <li>6. Defective gas control valve/thermostat</li> <li>7. Heater installed in a confined area</li> </ol>	<ol style="list-style-type: none"> <li>1. Unblock inlet air openings</li> <li>2. Provide ventilation to water heater. Check flue way, flue baffle and burner</li> <li>3. Check with gas utility company</li> <li>4. Replace with correct orifice (see rating plate)</li> <li>5. Clean, locate source and correct</li> <li>6. Replace gas control valve/thermostat</li> <li>7. Provide fresh air ventilation</li> </ol>
UNABLE TO LIGHT THE BURNER	<ol style="list-style-type: none"> <li>1. Air in gas line</li> <li>2. Pressure switch</li> <li>3. Blocked exhaust</li> <li>4. Wire connection</li> <li>5. Defective gas control valve/thermostat</li> </ol>	<ol style="list-style-type: none"> <li>1. Purge the air from gas line</li> <li>2. Check the pressure switch, make sure the pressure switch hose is not kinked</li> <li>3. Check vent pipe for blockage</li> <li>4. Check wire connections</li> <li>5. Replace the gas control valve/thermostat</li> </ol>
SIZZLING, RUMBLING NOISE	<ol style="list-style-type: none"> <li>1. Scale and sediment</li> <li>2. Condensation dripping on burner</li> </ol>	<ol style="list-style-type: none"> <li>1. Drain/flush-provide water treatment if needed</li> <li>2. Refer to "Condensate" section</li> </ol>
WATER LEAKAGE	<ol style="list-style-type: none"> <li>1. Condensation</li> <li>2. Dripping Temperature &amp; Pressure Relief Valve</li> <li>3. Drain valve dripping/leaking</li> <li>4. Tank Leak</li> </ol>	<ol style="list-style-type: none"> <li>1. Refer to "Condensate" section</li> <li>2. Refer to "Temperature-Pressure Relief Valve" section</li> <li>3. Back flush to clean- out sediment, replace if necessary.</li> <li>4. Check "Leakage Checkpoints"</li> </ol>
BLOWER WILL NOT START	<ol style="list-style-type: none"> <li>1. No power to unit</li> <li>2. Thermostat set too low</li> <li>3. Defective air pressure switch</li> <li>4. Defective blower</li> <li>5. Disconnected or loose wire</li> <li>6. Control locked out</li> </ol>	<ol style="list-style-type: none"> <li>1. Plug in power cord, check fuses and/or supply voltage</li> <li>2. Turn temperature knob to higher setting</li> <li>3. Replace air pressure switch</li> <li>4. Replace blower</li> <li>5. Repair and reconnect wires</li> <li>6. Refer to "Resetting The Heater Control" – determine cause of lockout</li> </ol>

PROBLEM	POSSIBLE CAUSE(S)	CORRECTIVE ACTION
BLOWER RUNS CONTINUOUSLY	<ol style="list-style-type: none"> <li>1. Air pressure switch not closing due to insufficient draft – check for:               <ol style="list-style-type: none"> <li>a. Vent piping blocked</li> <li>b. Piping length too long</li> <li>c. Clogged/dirty blower</li> </ol> </li> <li>2. Disconnected, torn or blocked pressure switch hose from air pressure switch to blower housing</li> <li>3. Defective pressure switch</li> <li>4. High limit switch open due to excessive vent temperature or defective switch</li> </ol>	<ol style="list-style-type: none"> <li>1. Determine cause of insufficient draft. Check draft with manometer at pressure switch               <ol style="list-style-type: none"> <li>a. Remove blockage</li> <li>b. Reduce vent length/increase vent size</li> <li>c. Clean blower wheel</li> </ol> </li> <li>2. Reconnect or replace pressure switch hose</li> <li>3. Replace defective pressure switch</li> <li>4. Determine cause of overheating check for: overfiring, insufficient air supply, high ambient air temperature</li> </ol>
HOT SURFACE IGNITER NOT GLOWING FOLLOWING WARM-UP PERIOD	<ol style="list-style-type: none"> <li>1. 120VAC polarity reversed at 120VAC outlet receptacle</li> <li>2. Defective hot surface igniter</li> <li>3. Defective gas control valve/thermostat</li> </ol>	<ol style="list-style-type: none"> <li>1. Reverse polarity at 120VAC outlet receptacle</li> <li>2. Replace igniter</li> <li>3. Replace gas control valve/thermostat</li> </ol>
VENT PIPE TOO HOT	<ol style="list-style-type: none"> <li>1. Blower high limit switch fails to open - switch defective</li> <li>2. Not enough dilution air to mix with flue gases</li> <li>3. Air in room too hot for mixing with flue gases</li> <li>4. Wrong burner orifice</li> </ol>	<ol style="list-style-type: none"> <li>1. Replace blower high limit switch</li> <li>2. Proper air circulation must be provided for combustion and dilution of flue temp</li> <li>3. Increase ventilation to lower room temperature</li> <li>4. Install correct orifice.</li> </ol>

## RESETTING THE HEATER CONTROL

- Soft lockouts as diagnosed by the system error codes require the gas control to be reset.
- To reset the control, slide the “ON/OFF” switch to the “OFF” position. Wait for 10 seconds and move the switch back to the “ON” position.
- If the problem that caused the control to lock out has not been corrected, the control will remain or again go back into lockout.

## LOCKOUTS

### Soft Lockout

- occurs when a system safety device trips to break the sequence of operation. The control will retry the system in a timed basis but will not reinstate operation until the failure is corrected.

### Hard Lockout

- occurs when the main controller fails and must be replaced.

The gas control valve\thermostat includes a temperature limiting ECO (Energy Cut Off) system that will shut off the water heater if the water temperature is too high. Should the water temperature get too high, the diagnostic status light will indicate a code (4 flashes), indicating an over-temperature condition and the main burner will be shut off. If a high temperature condition occurs, turn the main gas supply OFF and have the water heater repaired by a qualified service technician. Contact your local dealer for service information.

**Note:** Should an over-temperature condition occur, restart the water heater and verify the LED flash sequence. If the 4 flash sequence is observed, slide the “ON/OFF” switch to the “OFF” position. Turn Main Gas Supply “OFF”. Replace the gas control valve\thermostat.

## IGNITION STATE AND TIMING

IGNITION STATE	TIMING
Pre-purge	5 seconds (NG models)
	15 seconds (LP models)
Hot Surface Igniter (HSI) Warmup	10 seconds
Ignition Activation Period (IAP)	3.5 seconds maximum
Flame Recognition Period (FRP)	0.5 second
Trial For Ignition	IAP + FRP
Flame Stabilization Period	Not Applicable
Inter-purge	30 seconds
Flame Failure Response Time	2 seconds max (@ 1uA flame current)
Post-purge	30 seconds
Pressure Switch (PS) Prove Period	2 minutes
Pressure Switch (PS) Fault Delay (failed open/closed)	2 minutes
Soft Lockout	20 minutes
Energy Cut Off (ECO) Limit Lockout	Indefinite
Flammable Vapor (FV) Sensor Lockout	Indefinite (see “Resetting The Heater Control”)

## SYSTEM STATUS AND ERROR CODES

The micro-controller inside the gas control monitors the flammable vapor safety features, the ignition sequence, temperature settings and overall operation of the heater. If any of these parameters does not operate properly the controller will shut down the water heater, diagnose the failure and flash an error code. The table below lists the System Status Codes for the Honeywell control. Refer to it and to the “Troubleshooting Guidelines” to diagnose the problem before attempting corrective action. See also “Flammable Vapor Sensor”.

LED Flash Sequence	Control Status	Corrective Action Number
Short flash once every four seconds	IDLE (no call for heat, no fault conditions)	1
“Heartbeat”, alternates bright/dim	Call For Heat (no fault conditions)	2
One Flash, three second pause	Low Flame Signal (control continues to operate)	3
Two Flash, three second pause	Pressure Switch Failed Closed	4
Three Flash, three second pause	Pressure Switch Failed Open	5
Four Flash, three second pause	ECO (Energy Cut Off) Limit Lockout thermostat temperature limit was exceeded.	6
Five Flash, three second pause	Flame Out Of Sequence	7
Six-One Flash, three second pause	Soft Lockout - Retry Limit - Failed Trial For Ignition	8
Six-Two Flash, three second pause	Soft Lockout - Recycle Limit - Pressure Switch/ High Limit opened	9
Six-Three Flash, three second pause	Soft Lockout - Recycle Limit - Flame Lost	10
Six-Four Flash, three second pause	Soft Lockout - Flame out of Sequence Sensed	11
Seven Flash, three second pause	N/A (Flammable Vapor Sensor Lockout)	12
Eight-One Flash, three second pause	N/A (Flammable Vapor Sensor Fault Detected)	13
Eight-Two Flash, three second pause	Temperature Sensor Fault Detected	14
Eight-Three Flash, three second pause	Electronics Fault Detected	15
Eight-Four Flash, three second pause	Valve Fault Detected	16
LED continuously “ON”	Hard Lockout	17

### READING THE LED FLASH SEQUENCE.

The LED indicator light is active when the gas valve/thermostat is in operation. The light will normally show a flash sequence of a short flash once every four seconds or a “Heartbeat” of alternating bright/dim. Multiple flash codes indicate an error and can be read as follows:

Example: Corrective Action Number 9, Six-Two Flash, three second pause. For this code, the LED indicator light will make six bright flashes, pause for one second and then make two more bright flashes. The LED will pause for three seconds and repeat the six-two cycle of flashes.

Corrective Action Number	Corrective Action
1	Normal operation, no action necessary.
2	Normal operation, no action necessary.
3	<ol style="list-style-type: none"> <li>1. Flame rod not properly seated in flame, reposition rod.</li> <li>2. Clean flame sensor rod with fine steel wood to avoid lock-out.</li> </ol>
4	<ol style="list-style-type: none"> <li>1. Check that blower operates and does not have any blockages.</li> <li>2. Check that all wiring is correct.</li> <li>3. Ensure the air pressure sensing tubes are properly connected and not kinked or damaged.</li> <li>4. Ensure the air pressure switch is correct and the air pressure switch (N.O.) is not bypassed (jumpered).</li> <li>5. Turn power to the unit "OFF" – check for continuity of the air pressure switch (N.O.) with wires disconnected; <ol style="list-style-type: none"> <li>a. If the pressure switch contacts show continuity (closed circuit), replace the pressure switch,</li> <li>b. If the pressure switch contacts are open and all wiring is correct, replace the Gas Control.</li> </ol> </li> </ol>
5	<ol style="list-style-type: none"> <li>1. Ensure the blower is running - check for 120 VAC to the blower when the heating cycle begins. <ol style="list-style-type: none"> <li>a. If the Gas Control does not energize the blower - replace the Gas Control.</li> <li>b. If the blower fails to start when energized: <ol style="list-style-type: none"> <li>i. Turn power to the heater "OFF" – check if the capacitor is connected;</li> <li>ii. Turn power to the heater "OFF" – check the capacitor rating ( 3uF +/-5%);</li> <li>iii. Turn power to the heater "OFF" - replace the blower assembly.</li> </ol> </li> </ol> </li> <li>2. Ensure the air pressure sensing tubes are properly connected and not kinked or damaged;</li> <li>3. Check continuity of the vent temperature limit switch – replace switch if contact remain open.</li> <li>4. Check continuity of the air pressure switch (N.C.) – replace switch if contact remain open.</li> <li>5. Ensure the correct size of exhaust and air intake pipes were used per the instruction manual for vent length. Ensure maximum number of elbows or equivalent feet of both pipes was not exceeded.</li> <li>6. Ensure there are no obstructions in the exhaust and air intake pipes.</li> <li>7. If there are excessive restrictions in the air intake pipe the air pressure switch (N.C.) will open.</li> <li>8. Check air pressure switch performance - Check blower vacuum with a manometer - Compare with air pressure switch (N.O.) setting. If the air pressure switch proves defective – replace the air pressure switch (N.O.).</li> <li>9. If the air pressure switch (N.O.) performance test results prove the air pressure switch is working properly, and all other steps are followed, and fault code persist – replace the control.</li> </ol>
6	<p>Resetting the ECO (Energy Cut-Out) requires manual intervention. It cannot be reset by cycling power to the control.</p> <p>Reset Procedure</p> <ol style="list-style-type: none"> <li>1. Manual reset is performed by turning the set point knob to lowest set point position for a minimum of 10 seconds and then return it to the desired set point.</li> <li>2. The manual reset of the ECO can only be performed 2 times, after the ECO trips a third time, the gas valve will enter a hard lock out where the gas control will need to be replaced.</li> </ol>
7	<ol style="list-style-type: none"> <li>1. Turn the power "OFF" for 10-20 seconds then "ON" again to clear the fault code.</li> <li>2. Flame rod not properly seated in flame, reposition rod.</li> <li>3. Clean flame sensor rod with fine steel wood to avoid lock-out.</li> <li>4. Replace the control if the fault code persists.</li> </ol>

Corrective Action Number	Corrective Action
8	<ol style="list-style-type: none"> <li>1. Gas supply is turned off or gas pressure is too low. Ensure supply pressure and manifold gas pressures are within requirements. Manifold pressure is nonadjustable, if gas supply pressure proves correct and manifold pressure is off by more than 0.3" WC replace the control.</li> <li>2. Low supply voltage - should be 115 - 125 VAC</li> <li>3. Ensure flame sensor is making good contact with the burner flame and flame is steady.</li> <li>4. Ensure flame sensor is clean, use ultra- fine steel wool to clean flame sensor.</li> <li>5. Ensure the Hot Surface Igniter is positioned properly to provide consistent ignition.</li> <li>6. Check for any cracks in igniter assembly ceramic insulators - replace igniter assembly if damaged.</li> <li>7. Check resistance of igniter at room temperature (at the plug). Replace the igniter if resistance is not within 42-76 ohms at room temperature.</li> <li>8. Ensure correct size of exhaust and air intake pipes were used per the instruction manual for vent length. Ensure maximum number of elbows or equivalent feet of both pipes was not exceeded.</li> </ol>
9	<ol style="list-style-type: none"> <li>1. Ensure the blower is running - check for 120 VAC to the blower when the heating cycle begins. <ol style="list-style-type: none"> <li>a. If the Gas Control does not energize the blower - replace the Gas Control.</li> <li>b. If the blower fails to start when energized: <ol style="list-style-type: none"> <li>i. Turn power to the unit "OFF" – check if the capacitor is connected;</li> <li>ii. Turn power to the unit "OFF" – check the capacitor rating ( 3uF +/-5%);</li> <li>iii. Turn power to the unit "OFF" - replace the blower assembly.</li> </ol> </li> </ol> </li> <li>2. Ensure the air pressure sensing tubes are properly connected and not kinked or damaged;</li> <li>3. Check continuity of the vent temperature limit switch – replace switch if contacts remain open.</li> <li>4. Check continuity of the air pressure switch (N.C.) – replace switch if contacts remain open.</li> <li>5. Ensure correct size of exhaust and air intake pipes were used per the instruction manual for vent length. Ensure maximum number of elbows or equivalent feet of both pipes was not exceeded.</li> <li>6. Ensure there are no obstructions in the exhaust and air intake pipes.</li> <li>7. If there are excessive restrictions in the air intake pipe the air pressure switch (N.C.) will open.</li> <li>8. Check air pressure switch performance - Check blower vacuum with a manometer - Compare with air pressure switch (N.O.) setting. If the air pressure switch proves defective – replace the air pressure switch (N.O.).</li> <li>9. If the air pressure switch (N.O.) performance test results prove the air pressure switch is working properly, and all other steps are followed, and fault code persist – replace the control.</li> </ol>
10	<ol style="list-style-type: none"> <li>1. Gas supply is turned "OFF" or gas pressure is too low. Ensure supply pressure and manifold gas pressures are within requirements. Manifold pressure is nonadjustable. If supply pressure proves correct and manifold, pressure is off by more than 0.3" WC replace the control.</li> <li>2. Low supply voltage - should be 115 - 125 VAC</li> <li>3. Ensure flame sensor is making good contact with the burner flame and flame is steady.</li> <li>4. Ensure the flame sensor is clean, use ultra-fine steel wool to clean flame sensor.</li> <li>5. Ensure the Hot Surface Igniter is positioned properly to provide consistent ignition.</li> <li>6. Check for any cracks in igniter assembly ceramic insulators - replace igniter assembly if damaged.</li> <li>7. Check resistance of igniter at room temperature (at the plug). Replace the igniter if resistance is not within 42-76 ohms at room temperature.</li> <li>8. Ensure correct size of exhaust and air intake pipes were used per the instruction manual for vent length. Ensure maximum number of elbows or equivalent feet of both pipes was not exceeded.</li> </ol>
11	<ol style="list-style-type: none"> <li>1. Turn the power "OFF" for 10-20 seconds then "ON" again to clear the fault code.</li> <li>2. Replace the control if fault code persists.</li> </ol>
12	N/A – If this happens replace the gas control.
13	N/A – If this happens replace the gas control.
14	<ol style="list-style-type: none"> <li>1. Turn the power "OFF" for 10-20 seconds then "ON" again to clear the fault code.</li> <li>2. Replace the control if the fault code persist.</li> </ol>
15	<ol style="list-style-type: none"> <li>1. Turn the power "OFF" for 10-20 seconds then "ON" again to clear the fault code.</li> <li>2. Replace the control if the fault code persist.</li> </ol>
16	<ol style="list-style-type: none"> <li>1. Turn the power "OFF" for 10-20 seconds then "ON" again to clear the fault code.</li> <li>2. Replace the control if the fault code persist.</li> </ol>
17	1. Control has failed. If resetting the control does not clear the fault code, replace the control.



# NOTES

# NOTES

# NOTES



500 Tennessee Waltz Parkway,  
Ashland City, TN 37015

- Technical Support: 800-527-1953
- Parts: 800-433-2545
- Fax: 800-644-9306

[www.hotwater.com](http://www.hotwater.com)

Copyright © 2013 A. O. Smith Corporation. All rights reserved.